

HONEST

POWER TOOLS

Mod. Z1J – KA9 – 13/16



IMPORTANT

LIRE AVANT USAGE

IMPORTANT

READ BEFORE USING



MANUEL D'UTILISATION

USER'S MANUAL

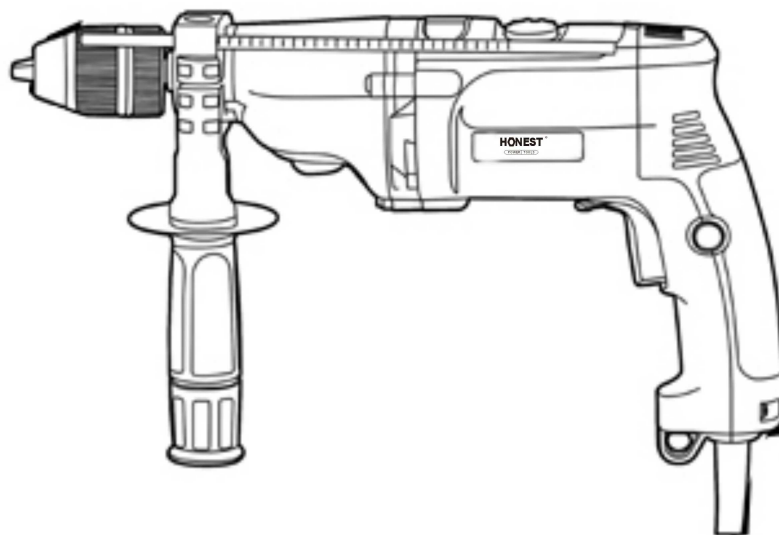

FRANCAIS

Page 2

ENGLISH

Page 11

PRINCIPALES CONSIGNES DE SECURITE POUR APPAREIL ELECTRO-PORTATIF



AVERTISSEMENT

LORS DE L'USAGE DE TOUT APPAREIL ELECTRO-PORTATIF, LES CONSIGNES DE SECURITE ELEMENTAIRES DOIVENT ETRE OBSERVEES POUR EVITER LES RISQUES D'ELECTROCUTION, D'INCENDIE ET/OU DE BLESSURES PHYSIQUES. LIRE ET COMPRENDRE CE MANUEL D'UTILISATEUR IS INDISPENSABLE AVANT DE FAIRE FONCTIONNER VOTRE APPAREIL ELECTRO-PORTATIF.

SECURITE ELECTRIQUE DE BASE

DOUBLE ISOLATION. CET OUTIL EST DOUBLEMENT ISOLE DE LA PRINCIPALE SOURCE GENERATRICE DE COURANT. IL N'EST DONC PAS NECESSAIRE DE LE RELIER A UNE PRISE TERRE.

COMPATIBILITE ENTRE LA TENSION DU SECTEUR ET LA TENSION DE L'APPAREIL. VERIFIER AVANT TOUT BRANCHEMENT DE L'APPAREIL QUE LA TENSION DU SECTEUR EST COMPATIBLE AVEC CELLE DE L'APPAREIL.

EVITEZ L'ELECTROCUTION. NE PAS TRAVAILLER DANS DES CONDITIONS HUMIDES ET MOUILLEES.

SECURITE DES PERSONNES DE BASE

SOYEZ VIGILANT. UTILISER UN APPAREIL ELECTRO-PORTATIF EXIGE ATTENTION, CONCENTRATION ET CONTROLE DE SOI AFIN D'EVITER DES ACCIDENTS. AUSSI, QUAND VOUS UTILISEZ UN APPAREIL, VOUS NE DEVEZ PAS ETRE EN ETAT DE FATIGUE OU SOUS L'EFFET DE L'ALCOOL, DE LA DROGUE OU DES MEDICAMENTS.

PORTEZ DES PROTECTIONS. UTILISER DES PROTECTIONS TELS QUE LUNETTES, MASQUES ANTI-POUSSIERE, CHAUSSURES ANTI-DERAPANTES, CASQUES, ET/OU UN APPAREILLAGE ANTI-BRUIT SELON LES SITUATIONS.

HABILLEZ DE MANIERE APPROPRIEE. NE PAS PORTER DE VETEMENTS AMPLES NI DE BIJOUX QUI PEUVENT ETRE ACCROCHES PAR LES PIECES EN ROTATION DE L'APPAREIL ELECTRO-PORTATIF.

ENLEVEZ LES OUTILS DE REGLAGE AVANT DE FAIRE FONCTIONNER L'APPAREIL ELECTRO-PORTATIF.

AVANT DE BRANCHER VOTRE APPAREIL, ENLEVER TOUT OUTIL DE REGLAGE COMME LA CLE DE SERRAGE AFIN D'EVITER UN ACCIDENT PROVOQUE PAR LA ROTATION DE L'OUTIL DE SERRAGE ACCROCHE A UNE PIECE TOURNANTE DE L'APPAREIL ELECTRO-PORTATIF.

EVITEZ LES DEMARRAGES ACCIDENTELS. ASSUREZ-VOUS QUE L'INTERRUPTEUR SOIT EN POSITION "ARRET" ("OFF") AVANT DE BRANCHER VOTRE APPAREIL.

EVITEZ L'ELECTROCUTION OU DES DOMMAGES ACCIDENTELS. TOUJOURS TENIR VOTRE APPAREIL ELECTROPORTATIF PAR LES SURFACES ISOLEES LORSQUE VOUS FAITES DES PERCAGES OU DES DECOUPAGES CAR VOUS POUVEZ ETRE EN CONTACT AVEC DES FILS ELECTRIQUES OU AVEC DES TUYAUX DE GAS CACHES.

MAINTENEZ VOTRE APPAREIL ET VOS MAINS EN ETAT DE PROPRETE. GARDER VOTRE APPAREIL, NOTAMMENT LES POIGNEES, AINSI QUE VOS MAINS PROPRES ET EXEMPTES DE TOUTE TRACE D'HUILE OU DE GRAISSE AFIN D'AVOIR UNE MEILLEURE PRISE EN MAIN DE VOTRE APPAREIL EN ETAT DE MARCHE.

TENEZ VOTRE APPAREIL A L'ECART DES ENFANTS.



PRECAUTIONS D'USAGE ET ENTRETIEN

DE L'APPAREIL ELECTRO-PORTATIF

N'UTILISEZ PAS UN APPAREIL DANS UN CONTEXTE INAPPROPRIE. CHAQUE APPAREIL EST CONCU POUR UNE PERFORMANCE SPECIFIQUE. UN APPAREIL DESTINE AU BRICOLEUR N'EST PAS ADAPTE A UN USAGE PROFESSIONNEL.

FAITES REPARER VOTRE APPAREIL PAR UN REPARATEUR QUALIFIE. TOUT APPAREIL PRESENTANT DES DEFAUTS AU NIVEAU DES REGLAGES PEUT REPRESENTER UN DANGER ET DOIT ETRE REPARÉ PAR UNE REPARATEUR QUALIFIE.

DEBRANCHEZ VOTRE APPAREIL AVANT TOUTE INTERVENTION. DEBRANCHER VOTRE APPAREIL DE LA PRISE DE COURANT OU DE SON PACK BATTERIE AVANT DE FAIRE DES REGLAGES, DES CHANGEMENTS D'ACCESSOIRES, DE STOCKER

VOTRE APPAREIL, OU D'EFFECTUER DES OPERATIONS DE MAINTENANCE.

RANGÉZ VOTRE APPAREIL DANS UN LIEU SUR. RANGER VOTRE APPAREIL DANS UN LIEU SEC ET PROPRE, ET A L'ECART DES ENFANTS.

MAINTENEZ A TITRE PREVENTIF VOTRE APPAREIL

- VERIFIEZ FREQUEMMENT LES PARTIES ASSEMBLEES ET REVISEZ LES VIS DESERREES.
- GRAISSEZ LES APPAREILS DISPOSANT DES PIECES MONTEES AVEC ENGRENAGE AU MOYEN D'UN LUBRIFIANT A CHAQUE REMPLACEMENT DE BALAI A CHARBON.
- EXAMINEZ REGULIEREMENT L'ETAT DES BALAIS A CHARBON.
- NETTOYEZ LE CORPS DE VOTRE APPAREIL EN UTILISANT UN CHIFFON HUMECTE LEGEREMENT AVEC UNE SOLUTION D'EAU ET DE SAVON.

PRINCIPALES CONSIGNES DE SECURITE POUR PERCEUSE A PERCUSSION

EVITEZ DES ELECTROCUTIONS. TOUJOURS TENIR VOTRE APPAREIL PAR LES SURFACES ISOLEES LORSQUE VOUS EFFECTUEZ UNE OPERATION DE PERCAGE QUI RISQUE METTRE VOTRE APPAREIL AU CONTACT AVEC DES FILS ELECTRIQUES CACHES.

PORTEZ DES EQUIPEMENTS DE PROTECTION. PORTER DES LUNETTES DE PROTECTION LORS DE L'USAGE DE VOTRE PERCEUSE AFIN D'EVITER LA BLESSURE PAR PROJECTION DE DEBRIS.

GARDEZ VOTRE EQUILIBRE ET EVITEZ DES ENTORSES. NE PAS ENROULER LE CORDON D'ALIMENTATION AUTOUR DE VOTRE POIGNEE, BRAS OU DE VOTRE TAILLE POUR NE PAS ETRE PRIS EN DESEQUILIBRE.

POSITIONNEZ VOUS DE MANIERE A NE PAS ETRE PRIS ENTRE L'APPAREIL OU LA POIGNEE ET LES SURFACES DE TRAVAIL. EN CAS DE BLOCAGE DU FORET DANS L'OUVRAGE, LE COUPLE DE REACTION PEUT TORDRE VOTRE MAIN OU VOTRE PIED.

EVITER DE PERDRE LE CONTROLE DE VOTRE APPAREIL. LOGEZ BIEN LES FORETS A L'INTERIEUR DES MACHOIRES DU MANDRIN AVANT DE RESERRER LE MANDRIN.

EN CAS DE GRIPAGE DU FORET DANS UN OUVRAGE, RELACHEZ LA GACHETTE "MARCHE/ARRET" ; INVERSEZ LE SENS DE ROTATION, ET RETIREZ AVEC UNE VITESSE LENTE LE FORET GRIPÉ.

NE METTEZ PAS VOS MAINS TROP PROCHE DES FORETS OU DES EMBOUTS EN ROTATION POUR



EVITER DES BLESSURES.

APRES UN USAGE PROLONGE, LE FORET EST TRES CHAUD. PORTEZ DONC DES GANTS POUR RETIRER LES FORETS AFIN D'EVITER DES BRULURES.

NE FORCEZ PAS VOTRE PERCEUSE A PERCUSSION EN MARCHE. TROP DE PRESSION RALENTIT LA VITESSE DE VOTRE APPAREIL ET PROVOQUE UNE SURCHARGE POUVANT ENTRAENER LE DEGAT DU MOTEUR ELECTRIQUE DE VOTRE APPAREIL.

SYMBOLES

IMPORTANT: CERTAINS SYMBOLES MENTIONNES CI-DESSOUS PEUVENT ETRE IMPRIMES SUR VOTRE APPAREIL. LA COMPREHENSION DE CES SYMBOLES VOUS PERMET D'UTILISER VOTRE APPAREIL DANS DE MEILLEURES CONDITIONS DE SECURITE.

SYMBOLE	NOM	DESIGNATION / EXPLICATION
V	VOLT	TENSION
A	AMPERE	COURANT
Hz	HERTZ	FREQUENCE
W	WATT	PUISSANCE
n0	REGIME A VIDE	VITESSE A VIDE
.../MIN	REVOLUTION PAR MINUTE	NOMBRE DE ROTATION / MINUTE
0	POSITION D'ARRET	VITESSE NULLE
1, 2, 3, ...OU I, II, III,	SELECTEUR DE VITESSE	UN CHIFFRE ELEVE INDIQUE 1 VITESSE PLUS GRANDE
	CONSTRUCTION CLASSE II	DOUBLE ISOLATION
	TERMINALE TERRE	LIAISON TERRE
	PROTECTION ENVIRONNEMENT	LES PRODUITS ELECTRIQUES USAGES NE DOIVENT PAS ETRE JETES AVEC VOS AUTRES ORDURES MENAGERES. RECYCLEZ-LES SI LES INSTALLATIONS APPROPRIEES EXISTENT. DEMANDEZ CONSEIL AUPRES DE VOTRE AUTORITE LOCALE OU DE VOTRE REVE

PRINCIPALES FONCTIONS DE LA PERCEUSE A PERCUSSION

VOTRE PERCEUSE A PERCUSSION DISPOSE TOUT OU PARTIE DES FONCTIONS SUIVANTES :

PRINCIPALES FONCTIONS DE LA PERCEUSE A PERCUSSION

MODELE Z1J – HT – 13

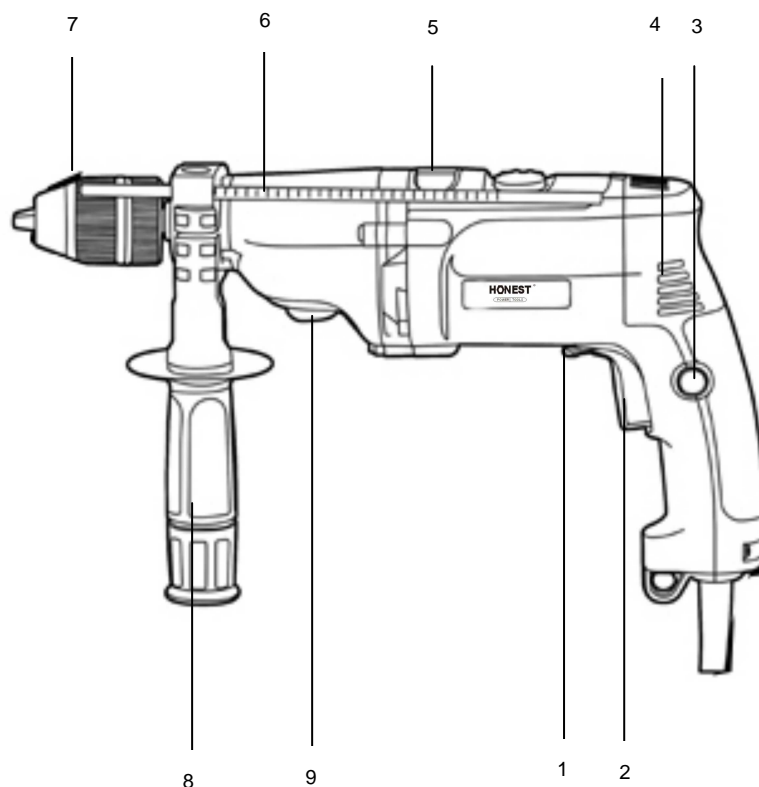

1. LEVIER DE MARCHE "AVANT/ARRIERE"
2. GACHETTE DE "MARCHE/ARRET" ET DE COMMANDE A VITESSE VARIABLE
3. BOUTON DE BLOCAGE EN MARCHE
4. VENTILATION
5. CADRAN DE SELECTION DE PERCAGE/PERCUSSION
6. BUTEE DE PROFONDEUR
7. MANDRIN AUTO
8. POIGNEE AUXILIAIRE
9. REDUCTEUR BIETAGE

PERCEUSE A PERCUSSION EN OPERATION

LES PHOTOS ET/OU CROQUIS CI-DESSOUS ONT POUR BUT DE VOUS FAMILIARISER AVEC VOTRE PERCEUSE A PERCUSSION. CES PHOTOS ET/OU CROQUIS NE MONTRENT PAS FORCEMENT LE MODELE DE PERCEUSE QUE VOUS AVEZ ACHETE. **AVANT TOUTE MANIPULATION, VOTRE APPAREIL DOIT ETRE DEBRANCHE DU COURANT DE SECTEUR.**

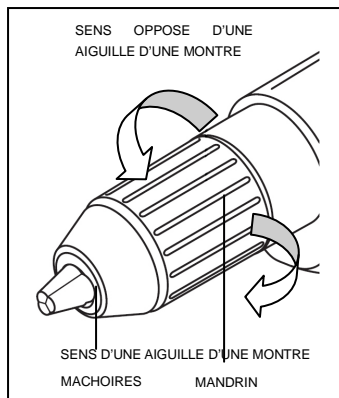

FIG. 1

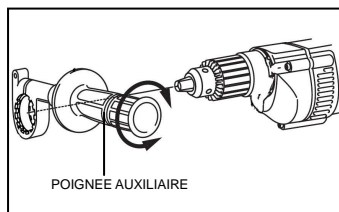

FIG. 2

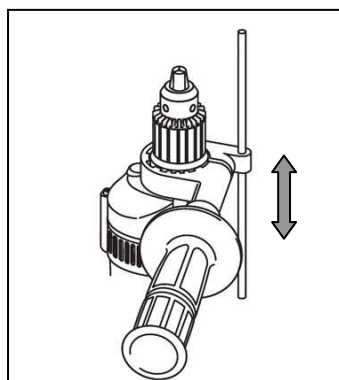

FIG. 3

INSTALLATION

1. INSERER OU ENLEVER UN FORET

PLACER LE LEVIER DE MARCHE "AVANT/ARRIERE" SUR LA POSITION "L". EMPLOYER LE MANDRIN AVEC UNE MAIN, DESERRER LES MACHOIRES DU MANDRIN EN FAISANT TOURNER LA PERCEUSE A PETITE VITESSE. PLACER LE LEVIER DE MARCHE "AVANT/ARRIERE" SUR LA POSITION "R". EMPLOYER LE MANDRIN D'UNE SEULE MAIN EN FAISANT TOURNER LA PERCEUSE A PETITE VITESSE (FIG. 1).

POUR RETIRER LE FORET, FAITES ETAPE PAR ETAPE LES OPERATIONS INVERSES DECRITES PLUS HAUT.

2. INSTALLER OR RETIRER LA POIGNEE AUXILIAIRE

LA POIGNEE AUXILIAIRE DONNE PLUS DE CONTROLE ET DE SUPPORT A VOTRE PERCEUSE A PERCUSSION. CETTE POIGNEE EST ORIENTABLE A 360° AUTOUR DE SON AXE DE ROTATION (FIG.2).

3. INSTALLER LA BUTEE DE PROFONDEUR

LA BUTEE DE PROFONDEUR EST PRATIQUE POUR PERCER LES TROUS AVEC UNE PROFONDEUR UNIFORME. DESERRER LA POIGNEE AUXILIAIRE ET INSERER LA BUTEE DE PROFONDEUR DANS LE TROU PREVU. AJUSTER LA PROFONDEUR DE PERCAGE DESIREE ET SERRER LA POIGNEE LATERALE (FIG. 3).

4. REMPLACER LE CHARBON

POUR MAINTENIR L'EFFICACITE MAXIMALE DU MOTEUR DE VOTRE APPAREIL, NOUS RECOMMANDONS QUE VOUS INSPECTEZ L'ETAT DU CHARBON TOUS LES 2 A 6 MOIS. COMME LE CHARBON EST LOCALISE A L'INTERIEUR DE VOTRE APPAREIL, L'ENTRETIEN DOIT ETRE ASSURE PAR UN PERSONNEL QUALIFIE.

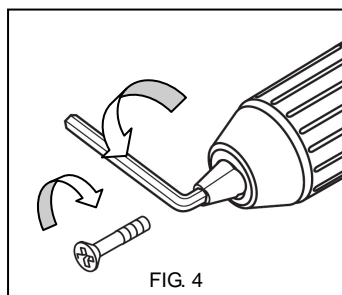

FIG. 4

5. ENLEVER ET INSTALLER LE MANDRIN

POUR ENLEVER LE MANDRIN, DESERRER D'ABORD LES MACHOIRES DU MANDRIN ET DEVISSER LA VIS PLACEE A L'INTERIEUR DU MANDRIN AVEC UN TOURNEVIS (FIG. 4). CHOISIR ENSUITE UNE CLE HEXAGONALE, L'INSERER A L'INTERIEUR DU MANDRIN ET LA FAIRE TOURNER DANS LE SENS OPPOSE DE ROTATION D'UNE AIGUILLE D'UNE MONTRE.

OPERATION

1. FONCTION OPERATION CONTINUE

APPUYER SUR LA GACHETTE "MARCHE/ARRET" POUR DEMARRER D'ABORD VOTRE PERCEUSE A PERCUSSION. ENSUITE, APPUYER SUR LE BOUTON DE BLOCAGE EN MARCHE POUR ACTIVER L'OPTION OPERATION EN CONTINU. POUR DESACTIVER LA FONCTION OPERATION EN CONTINU, APPUYER SUR LA GACHETTE "MARCHE/ARRET" POUR ARRETER VOTRE APPAREIL (FIG. 5)

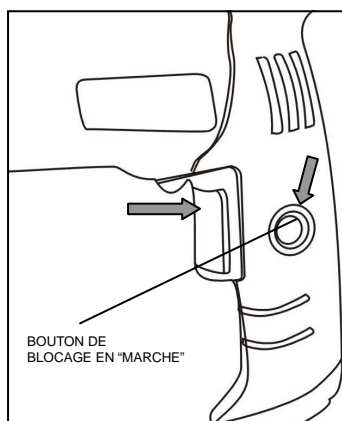

FIG. 5

2. FONCTION SELECTION "VITESSE VARIABLE"

VOTRE APPAREIL EST EQUIPE DE DEUX VITESSES ASSOCIEES CHACUNE A UNE VITESSE VARIABLE PERMETTANT A VOTRE APPAREIL DE TOURNER ENTRE 0 A 1,200 ET ENTRE 0 A 2,900 TOURS PAR MINUTE. LE SYMBOLE "I" REPRESENTE LA VITESSE LENTE ALORS QUE LE SYMBOLE "II" REPRESENTE LA VITESSE RAPIDE. POUR OBTENIR UN PERCAGE DE PRECISION, UTILISER UNE VITESSE LENTE POUR MARQUER UN POINT D'ENTREE DE PERCAGE ; ENSUITE, ACCROITRE LA VITESSE POUR PENETRER LA PIECE A TRAVAILLER (FIG. 6).

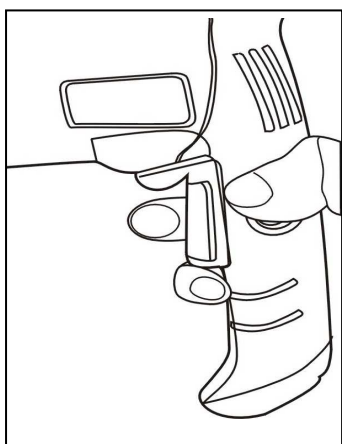

FIG. 6

3. FONCTION REVERSIBLE

VOTRE PERCEUSE A PERCUSSION POSSEDE LA FONCTION REVERSIBLE : POUR UNE ROTATION "AVANT", DEPLACER LE LEVIER MARCHE "AVANT/ARRIERE" VERS LA POSITION "R" ; POUR UNE ROTATION "ARRIERE", DEPLACER LE MEME LEVIER VERS LA POSITION "L" (FIG. 8). SI LE LEVIER MARCHE "AVANT/ARRIERE" EST PLACE AU CENTRE, VOTRE PERCEUSE A PERCUSSION NE FONCTIONNERA PAS.

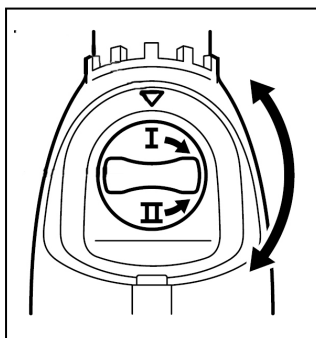

FIG. 7

4. FONCTION "PERCAGE/PERCUSSION"

POUR SELECTIONNER LA FONCTION "PERCAGE", POSITIONNER LE



FIG. 8

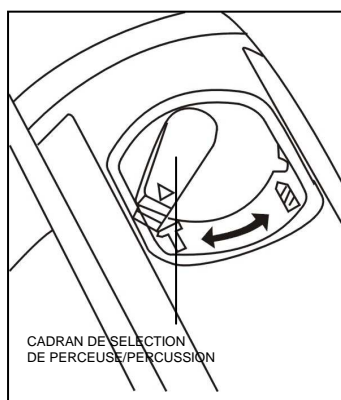



FIG. 9

SELECTEUR "PERCAGE/PERCUSSION" SUR LA POSITION DU SYMBOLE  REPRESENTANT LA FONCTION PERCAGE. POUR SELECTIONNER LA FONCTION "PERCUSSION", POSITIONNER LE MEME SELECTEUR SUR LE SYMBOLE  REPRESENTANT LA FONCTION PERCUSSION (FIG. 9).

5. ENLEVER ET INSTALLER LE MANDRIN

•PERCER LE BOIS OU LE PLASTIQUE

SERRER LA PIECE A TRAVAILLER POUR LA STABILISER. LORS DU PERCAGE DE MATERIAU FIN, IL EST RECOMMENDE D'UTILISER UNE CALE EN BOIS POUR EVITER LA FISSURATION DE LA PIECE.

•PERCER LES METAUX

POUR FACILITER LE PERCAGE, FAITES UN TROU AU POINCON DANS LA PIECE A TRAVAILLER. SI LE TROU A PERCER EST LARGE, FAIRE D'ABORD UN PETIT TROU. PUIS, ELARGIR LE PETIT TROU A LA TAILLE DESIREE. PARFOIS, VOUS AUREZ BESOIN D'HUILE DE COUPE POUR LUBRIFIER LA POINTE DU FORET AFIN DE FACILITER LE PERCAGE.

•PERCER LA MACONNERIE

UTILISER DES FORETS A POINTE EN CARBURE POUR LE PERCAGES DE MACONNERIE. LA PRESSION A EXERCER SUR VOTRE PERCEUSE A PERCUSSION DEPEND DE LA DURETE DU MATERIAU A PERCER.

PRINCIPALES DONNEES TECHNIQUES

MODELE	Z1J-KA9-13/16	
PUISSANCE NOMINALE	850 W	
TENSION	3.9 A	
VOLTAGE / FREQUENCE	230 V ~ 50 Hz	
DIAMETRE MAX. DU MANDRIN	13/16 MM	
REGIME A VIDE	0 – 2,900 / 0-1,200 TR/MIN	
PROFONDEUR DE PERCAGE MAX.	VITESSE RAPIDE (0-2,900 TR/MIN)	VITESSE LENTE (0-1,200 TR/MIN)
- BETON	20 MM	...
- BOIS	8 MM	16 MM
- ACIER	25 MM	40 MM
BRUIT ET VIBRATION		
- NIVEAU DE PRESSION SONORE	55.7 dB (A)	
- NIVEAU DE PUISSANCE SONORE	66.7 dB (A)	
- NIVEAU DE VIBRATION	M/S ²	
POIDS	3.2 KG	

ACCESSOIRES STANDARD

BUTÉE DE PROFONDEUR	1 PC
POIGNEE AUXILIAIRE	1 PC
BALAIS OU CHARBON	1 PAIRE
MANUEL D'UTILISATION	1 PC

DIAGRAMME DES PIECES DETACHEES DE LA PERCEUSE A PERCUSSION

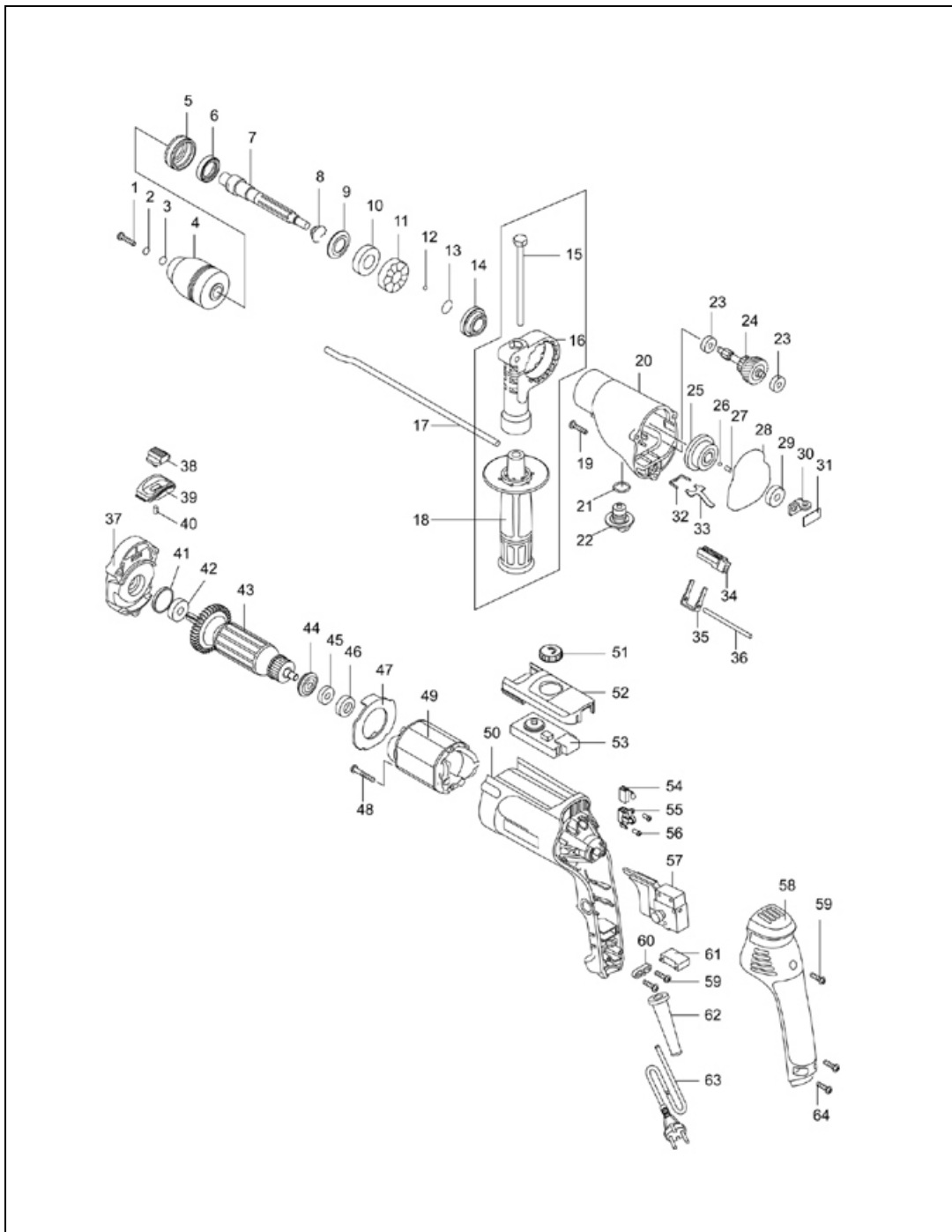

LISTE DES PIECES DETACHEES (VOIR LOCATION PRECISE)

NO. PIECE	DESCRIPTION	QUANTITE	NO. PIECE	DESCRIPTION	QUANTITE
1	SCREW M5 X 22	1	33	INSERTING PLATE	1
2	SPRING WASHER 5	1	34	GEAR TEETH	1
3	PLAIN WASHER 5	1	35	SPEED LEVER	1
4	CHUCK	1	36	FIXING PIN	1
5	BEARING COVER	1	37	MIDDLE COVER	1
6	SEAL	1	38	IMPACT BUTTON	1
7	SPRINDLE	1	39	BUTTON SEAT	1
8	IMPACT SPRING	1	40	PIN	1
9	SPRING SEAT	1	41	BEARING 609-2RZ	1
10	BEARING 6202-2R2	1	42	ROTAR ASSY	1
11	POSITIVE IMPACT BLOCK	1	43	DUST RING	1
12	STEEL BALL $\Phi 4$	1	44	O RING 26 X 29 X 3	1
13	CIRCLIP 12	1	45	BEARING 607-22	1
14	STILL IMPACT BLOCK	1	46	607 BEARING SLEEVE	1
15	BOLT M 8 X 115	1	47	WING GUARD	1
16	HANDLE CLAMP	1	48	SCREW ST 4.2 X 70 F	2
17	DEPTH GAUGE	1	49	STATOR ASSY	1
18	SIDE HANDLE	1	50	HOUSING	1
19	SCREW ST 4.2 X 35F	3	51	SPEED ADJUST DIAL	1
20	GEAR BOX	1	52	CONSTANT POWER SEAT	1
21	O RING	1	53	CONSTANT POWER	1
22	SPEED CHAG KNOB	1	54	CARBON BRUSH	2
23	BEARING 606-2Z	2	55	BRUSH HOLDER	2
24	MIDDLE SHAFT AND GEAR	1	56	SCREW ST 2.9 X 8	4
25	II BIG GEAR	1	57	SWITCH	1
26	STEEL BALL	1	58	REAR COVER	1
27	IMPACT PIN	2	59	SCREW 4.2 X 12F	3
28	SEAL RING	1	60	CORD CLAMP	1
29	BEARING 608-2RZ	1	61	CAPACITOR	1
30	ADJUST BLOCK	1	62	CORD PROTECTOR	1
31	WASHER	1	63	CORD AND PLUG	1
32	SPRING	1	64	SCREW ST 4.2 X 16F	2

* REMARQUE : LES PIECES NO. 51 ET NO. 53 NE SONT PAS UTILISEES POUR LE MODELE Z1J-HT-13

MAIN SAFETY INSTRUCTIONS FOR POWER TOOLS

WHEN USING A POWER TOOL, THE FOLLOWING BASIC SAFETY PRECAUTIONS SHOULD ALWAYS BE TAKEN TO REDUCE THE RISK OF ELECTRIC SHOCK, OF FIRE AND / OR PERSONAL INJURY. **READ AND UNDERSTAND THE USER'S MANUAL BEFORE OPERATING THE POWER TOOL IS REQUIRED.**

BASIC ELECTRICAL SAFETY

DOUBLE INSULATION. THIS TOOL IS DOUBLE INSULATED FROM THE MAIN POWER SUPPLY MAKING IT UNNECESSARY FOR THIS POWER TOOL TO BE EARTHED.

OUTLET VOLTAGE AND POWER TOOL VOLTAGE COMPATIBILITY. MAKE SURE THAT THE OUTLET VOLTAGE IS WITHIN THE VOLTAGE RANGE OF THE POWER TOOL.

AVOID ELECTRICAL SHOCK. DO NOT WORK IN WET AND HUMIDE CONDITIONS WITH A POWER TOOL.

BASIC PERSONAL SAFETY

BE WATCHFUL. OPERATING A POWER TOOL REQUIRES ATTENTION, CONCENTRATION AND CONTROL TO AVOID ANY PERSONAL INJURY. THUS, WHILE USING A POWER TOOL YOU MUST NOT BE TIRED AND/OR UNDER THE INFLUENCE OF ALCOHOL, DRUGS OR MEDICATION.

USE SAFETY EQUIPMENT. USE APPROPRIATE SAFETY EQUIPMENT SUCH AS GOGGLES, DUST MASK, NON-SKID SAFETY SHOES, OR HEARING PROTECTION WHENEVER AND WHEREVER APPLICABLE.

DRESS PROPERLY. DO NOT WEAR LOOSE CLOTHING OR JEWELRY SUCH AS NECKLACE THAT CAN BE CAUGHT BY THE POWER TOOL MOVING PARTS.

REMOVE ANY ADJUSTING TOOL SUCH AS KEY OR WRENCH. BEFORE PLUG IN THE POWER TOOL, REMOVE ANY ADJUSTING TOOL TO AVOID ACCIDENT

CAUSED BY THE ROTATION OF THE ADJUSTING TOOLS LEFT ATTACHED TO A ROTATION PART.

AVOID ACCIDENTAL START. ENSURE THAT THE SWITCH IS IN THE "OFF" POSITION BEFORE PLUGGING IN THE POWER TOOL.

AVOID ELECTRICAL SHOCK. ALWAYS HOLD POWER TOOL BY INSULATED GRIPPING SURFACES, WHEN PERFORMING AN OPERATION WHERE THE DRILLING OR CUTTING TOOLS MAY CONTACT HIDDEN ELECTRICAL WIRES.

MAINTAIN THE POWER TOOL AND YOUR HAND CLEAN. KEEP POWER TOOL, NOTABLY THE HANDLE(S) AND YOUR HANDS CLEAN AND FREE FROM OIL AND GREASE TO ENSURE BETTER CONTROL OF THE POWER TOOL IN OPERATION.

KEEP CHILDREN AND UNTRAINED PEOPLE AWAY.

POWER TOOL USE AND CARE

DO NOT FORCE THE POWER TOOL. DO NOT USE THE POWER TOOL IN AN INAPPROPRIATE CONTEXT OR IN A CONTEXT THE POWER TOOL IS NOT DESIGNED FOR. EACH POWER TOOL IS DESIGNED FOR SPECIFIC PERFORMANCE. A POWER TOOL DESIGNED TO BE SERVED AS A DO-IT-YOURSELF TOOL SHOULD NOT BE USED BY PROFESSIONALS FOR EXTENDED USES

HAVE THE POWER TOOL REPAIRED BY QUALIFIED PEOPLE. ANY POWER TOOL THAT CANNOT BE CONTROLLED WITH THE SWITCH IS DANGEROUS AND MUST BE REPAIRED BY A QUALIFIED PERSON.

DISCONNECT THE POWER TOOL FROM THE POWER SOURCE BEFORE ANY INTERVENTION. DISCONNECT THE PLUG FROM THE POWER SOURCE AND/OR THE



BATTERY PACK BEFORE MAKING ANY ADJUSTMENT, CHANGING ACCESSORIES, STORING THE POWER TOOL, AND MAINTAINING THE POWER TOOL.

STORE POWER TOOLS IN A SAFE PLACE. STORE IDLE POWER TOOLS IN A DRY AND A CLEAN PLACE, OUT OF THE REACH OF CHILDREN.

MAINTAIN PREVENTIVELY THE POWER TOOL.

- INSPECT REGULARLY THE MOUNTING PARTS; CHECK IF ALL THE LOOSE SCREWS ARE PROPERLY TIGHTENED.

- REGREASE THE POWER TOOL WITH GEARS WITH SPECIAL LUBRICANT AT EVERY BRUSH CHANGE.

- AFTER REGULAR EXAMINATION OF THE STATE OF THE BRUSHES AND COMMUTATOR, SEE WHETHER THESE PARTS NEED TO BE CHANGED.

- CLEAN YOUR POWER TOOLS BODY USING A CLEANING CLOTH LIGHTLY WET WITH A MIXED SOLUTION OF WATER AND SOAP.

MAIN SAFETY INSTRUCTIONS FOR IMPACT DRILL

WEAR SAFETY PROTECTION. ALWAYS WEAR SAFETY GOOGLES OR EYE PROTECTION WHEN USING THE IMPACT DRILL TO PREVENT ANY PROJECTION THAT MAY DAMAGE YOUR EYES.

DO NOT WRAP THE CORD AROUND YOUR WRIST, ARM OR WAIST TO AVOID BEING DESTABILIZED.

DO NOT GRASP THE TOOL OR PLACE YOUR HANDS TOO CLOSE TO THE SPINNING CHUCK OR DRILL BIT. YOUR HAND MAY RUN THE RISK OF BEING INJURED.

POSITION YOURSELF TO AVOID BEING CAUGHT BETWEEN THE TOOL OR SIDE HANDLE AND WALLS. SHOULD THE BIT BECOME BOUND OR JAMMED IN THE WORK, THE REACTION TORQUE OF THE TOOL COULD CRUSH YOUR HAND OR LEG.

WHEN INSTALLING AN ACCESSORY, INSERT THE SHANK OF THE ACCESSORY DEEP ENOUGH IN THE



JAWS OF THE CHUCK TO PREVENT THE RISK OF LOSING THE CONTROL OF YOUR IMPACT DRILL.

AS DRILL BITS MAY BE HOT AFTER PROLONGED USE, WHEN REMOVING THE BIT FROM THE TOOL, AVOID ANY CONTACT WITH YOUR SKIN, AND USE PROPER PROTECTIVE GLOVES WHEN GRASPING THE BIT OR OTHER ACCESSORIES.

NEVER USE EXCESSIVE FORCE. TOO MUCH PRESSURE CAN REDUCE THE SPEED OF YOUR DRILL AND REDUCE ITS EFFICIENCY. THIS CAN RESULT IN AN OVERLOAD WHICH CAN CAUSE DAMAGE TO THE ELECTRIC MOTOR OF YOUR IMPACT DRILL.

SYMBOLS

IMPORTANT: CERTAIN SYMBOLS MENTIONED BELOW ARE PRINTED ON YOUR POWER TOOL. THE UNDERSTANDING OF THESE SYMBOLS WILL ALLOW YOU TO OPERATE YOUR POWER TOOL IN SAFER CONDITION.

SYMBOL	NAME	DESIGNATION / EXPLANATION
V	VOLT	VOLTAGE
A	AMPERE	CURRENT
Hz	HERTZ	FREQUENCY
W	WATT	POWER
n0	NO LOAD SPEED	TOOL'S SPEED BEFORE CONTACT WITH THE WORKPIECE
.../MIN	REVOLUTION PER MINUTE	NUMBER OF ROTATIONS / MINUTE
0	"OFF"	"OFF" POSITION
1, 2, 3, ...OU I, II, III,	SPEED SELECTOR	A HIGH NUMBER INDICATES A HIGHER SPEED
	CONSTRUCTION CLASSE II	DOUBLE INSULATION
	EARTH TERMINAL	EARTH TERMINAL LIAISON
	ENVIRONMENTAL PROTECTION FOR WASTE ELECTRICAL PRODUCTS	WASTE ELECTRICAL PRODUCTS SHOULD NOT BE DISPOSED OF WITH HOUSEHOLD WASTE. PLEASE RECYCLE WHERE FACILITIES EXIST. CHECK WITH YOUR LOCAL AUTHORITY OR RETAILER FOR RECYCLING ADVICE

IMPACT DRILL MAIN FUNCTIONS

YOUR IMPACT DRILL POSSESSES SOME OR ALL OF THE FOLLOWING FUNCTIONS:

IMPACT DRILL MAIN FUNCTIONS

MODEL Z1J – KA9– 13/16

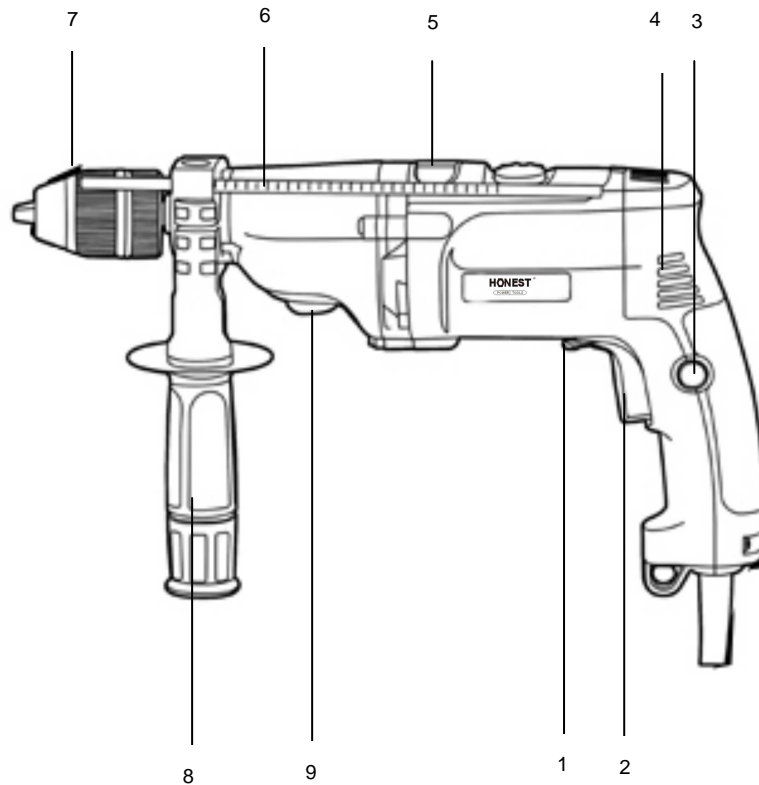

1. "FORWARD/REVERSE" LEVER
2. "ON/OFF" & "VARIABLE SPEED" SWITCH TRIGGER
3. "LOCK-ON" BUTTON
4. VENTILATION OPENINGS
5. DRILL/HAMMER SELECTOR DIAL
6. DEPTH GUIDE
7. KEYLESS CHUCK
8. SIDE HANDLE
9. TWO-SPEED GEARBOX UNIT

IMPACT DRILL IN OPERATION

THE PICTURES AND/OR THE DRAWINGS BELOW INTEND TO MAKE YOU FAMILAR WITH DIFFERENT FUNCTIONS OF YOUR IMPACT DRILL. THESE PICTURES AND/OR THE DRAWINGS MAY NOT SHOW THE ACTUAL IMPACT DRILL MODEL THAT YOU HAVE PURCHASED. **BEFORE ANY INTERVENTION, YOUR IMPACT DRILL MUST BE UNPLUGGED FROM THE POWER SOURCE.**

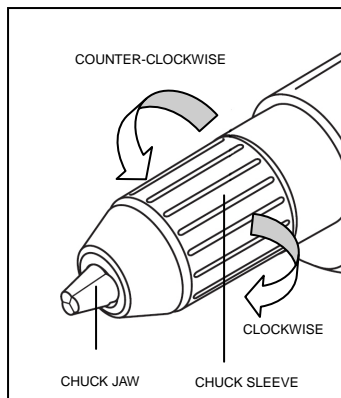

FIG. 1

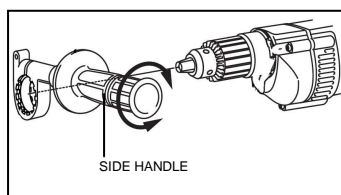

FIG. 2

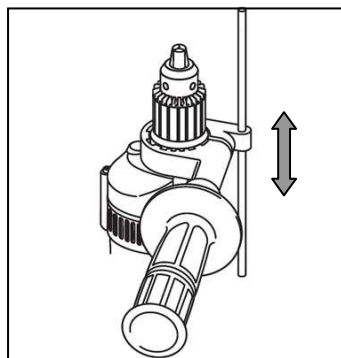

FIG. 3

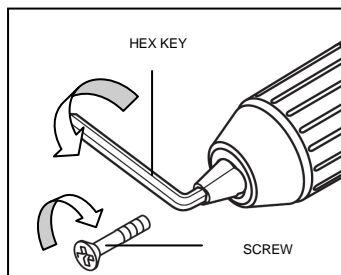

FIG. 4

ASSEMBLY

1. INSERTING OR REMOVING THE DRILL

PLACE "FORWARD/REVERSE" LEVER ON THE "L" POSITION. GRIP TIGHTLY THE CHUCK SLEEVE WITH ONE HAND, LOOSEN THE CHUCK JAWS BY TRIGGERING THE IMPACT DRILL AT LOW SPEED. INSERT THE DRILL INSIDE THE CHUCK. PLACE "FORWARD/REVERSE" LEVER TO THE "R" POSITION. GRIP TIGHTLY THE CHUCK SLEEVE WITH ONE HAND, TIGHTEN THE CHUCK JAWS BY TRIGGERING THE IMPACT DRILL AT LOW SPEED (FIG. 1).

REVERSE ALL THE OPERATIONS STEP BY STEP MENTIONED IN POINT 1. TO REMOVE THE DRILL.

2. INSTALLING OR REMOVING THE SIDE HANDLE

THE SIDE HANDLE PROVIDES ADDITIONAL CONTROL AND SUPPORT FOR THE IMPACT DRILL. THIS HANDLE IS ADJUSTABLE 360° AROUND ITS ROTATION AXIS (FIG. 2).

3. INSTALLING THE DEPTH GUIDE

THE DEPTH GUIDE IS CONVENIENT FOR DRILLING HOLES OF UNIFORM DEPTH. LOOSEN THE SIDE HANDLE AND INSERT THE DEPTH GUIDE INTO THE HOLE IN THE SIDE HANDLE. ADJUST THE DEPTH GUIDE TO THE DESIRED DEPTH AND TIGHTEN THE SIDE HANDLE (FIG. 3).

4. REPLACING THE CARBON BRUSHES

TO MAINTAIN THE PEAK EFFICIENCY OF YOUR POWER TOOL MOTOR, WE RECOMMEND THAT THE CARBON BRUSHES BE EXAMINED EVERY 2-6 MONTHS. AS THE CARBON BRUSHES ARE INTERNAL PARTS OF YOUR POWER TOOL, THE SERVICE MUST BE PERFORMED BY QUALIFIED PERSONNEL.



5. REMOVING OR INSTALLING THE CHUCK

TO REMOVE THE CHUCK, LOOSEN THE CHUCK JAWS AND REMOVE THE THREAD SCREW LOCATED INSIDE THE CHUCK WITH A SCREWDRIVER CLOCKWISE FIRST; THEN, CHOOSE A PROPER HEX KEY WRENCH, INSERT IT INSIDE THE CHUCK AND TURN IT COUNTER-CLOCKWISE (FIG. 4).

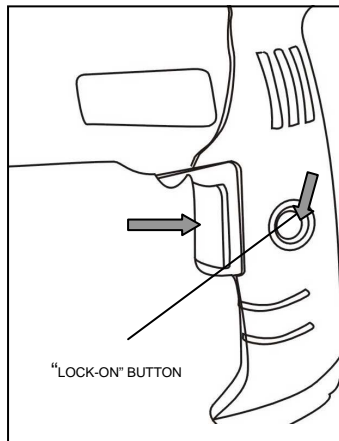

FIG. 5

OPERATION

1. CONTINUOUS OPERATION FUNCTION

DEPRESS THE "ON/OFF" TRIGGER SWITCH FIRST TO START YOUR IMPACT DRILL. THEN, PRESS ON THE "LOCK-ON" BUTTON TO ACTIVATE THE CONTINUOUS OPERATION OPTION. TO DESACTIVATE THE "LOCK-ON" FUNCTION, PRESS ON THE "ON/OFF" TRIGGER SWITCH TO STOP YOUR IMPACT DRILL.

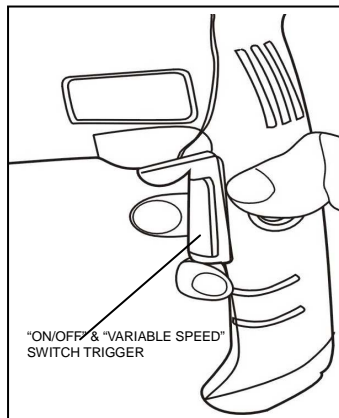

FIG. 6

2. "VARIABLE SPEED" SELECTION FUNCTION

YOUR IMPACT DRILL IS EQUIPPED WITH TWO-SPEED AND VARIABLE SPEED FUNCTIONS ALLOWING YOUR MACHINE TO RUN FROM 0 TO 1,200 RPM AND FROM 0 TO 2,900 RPM, THE SYMBOLE "I" IS LOW SPEED, AND THE SYMBOLE "II" IS HIGH SPEED (FIG. 7). TO GET A PRECISE DRILLING, USE A SLOW SPEED TO MARK AN ENTRY DRILLING POINT; THEN INCREASE THE SPEED TO PENETRATE THE WORK PIECE (FIG. 6).

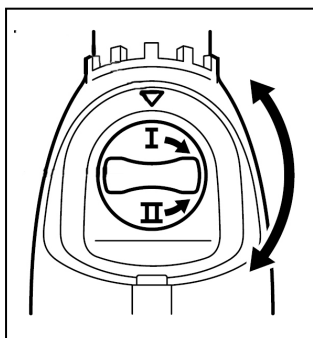

FIG. 7

3. "REVERSIBLE" FUNCTION

YOUR IMPACT DRILL POSSESSES THE REVERSIBLE FUNCTION: FOR "FORWARD" ROTATION, MOVE THE "REVERSIBLE" LEVER TO THE "R" POSITION; FOR "REVERSE" ROTATION, MOVE THE SAME LEVER POSITION TO THE "L" POSITION (FIG. 8). IF THE "REVERSIBLE" LEVER IS PLACED ON THE MIDDLE POSITION, YOUR IMPACT DRILL WILL NOT OPERATE.

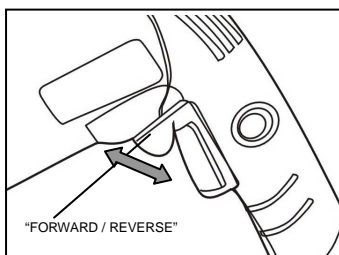

FIG. 8

CAUTION: TO PREVENT THE DAMAGE TO YOUR IMPACT DRILL, CHANGE THE ROTATION DIRECTION ONLY AFTER YOUR TOOL COMES TO A COMPLETE STOP.

4. "DRILL OR HAMMER" FUNCTION

TO SELECT THE "DRILL" FUNCTION, POSITION THE "DRILL/HAMMER" SELECTOR DIAL TO THE SYMBOL  REPRESENTING THE

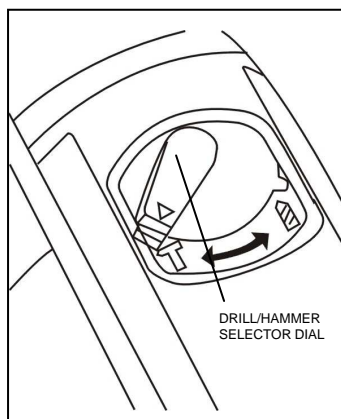



FIG 9

DRILLING FUNCTION. TO SELECT THE "HAMMER" FUNCTION, POSITION THE SAME LEVER TO THE SYMBOL  REPRESENTING THE HAMMER FUNCTION (FIG 9).

5. RECOMMENDATION FOR IMPACT DRILL OPERATIONS

• DRILLING WOOD OR PLASTIC

CLAMP OR ANCHORE THE WORKPIECE TO STABILISE IT. WHEN DRILLING THIN MATERIAL, IT IS RECOMMENDED TO USE A WOOD MADE "BACK-UP" BLOCK TO PREVENT WORKPIECE FROM SPLINTERING.

• DRILLING METALS

TO EASE THE DRILLING, MAKE A CENTRE PUNCH IN THE WORKPIECE. IF THE HOLE TO BE DRILLED IS LARGE, MAKE A SMALLER HOLE FIRST, THEN ENLARGE IT TO THE REQUIRED SIZE. SOMETIMES, YOU MAY NEED CUTTING OIL TO LUBRICATE THE TIP OF THE BIT TO FACILITATE THE DRILLING.

• DRILLING MASONARY

USE CARBIDE TIP BITS FOR ALL MASONARY DRILLING. THE PRESSURE APPLIED ON YOUR IMPACT DRILL DEPENDS ON THE HARDNESS OF THE MATERIAL BEING DRILLED.

MAIN TECHNICAL DATA

MODEL	Z1J-KA9-13/16	
RATED INPUT POWER	850 W	
RATED INPUT CURRENT	3.9 A	
VOLTAGE / FREQUENCY	230 V ~ 50 Hz	
MAX. CHUCK DIAMETER	13/16 MM	
NO-LOAD SPEED	0-2,900/0-1,200 RMP	
MAX. DRILLING CAPACITY	HIGH SPEED (0-2,900 RMP)	LOW SPEED (0-1,200 RMP)
- CONCRETE	20 MM
- WOOD	8 MM	16 MM
- STEEL	25 MM	40 MM
NOISE AND VIBRATION		
- SOUND PRESSURE LEVEL	55.7 dB (A)	
- SOUND POWER LEVEL	66.7 dB (A)	
- VIBRATION LEVEL	25.4 M/S ²	
WEIGHT	3.2 KG	

STANDARD ACCESSORIES

DEPTH GUIDE	1 PC
SIDE HANDLE	1 PC
CARBON BRUSHES	1 PAIR
INSTRUCTION MANUAL	1 PC

IMPACT DRILL SPARE PARTS DIAGRAM

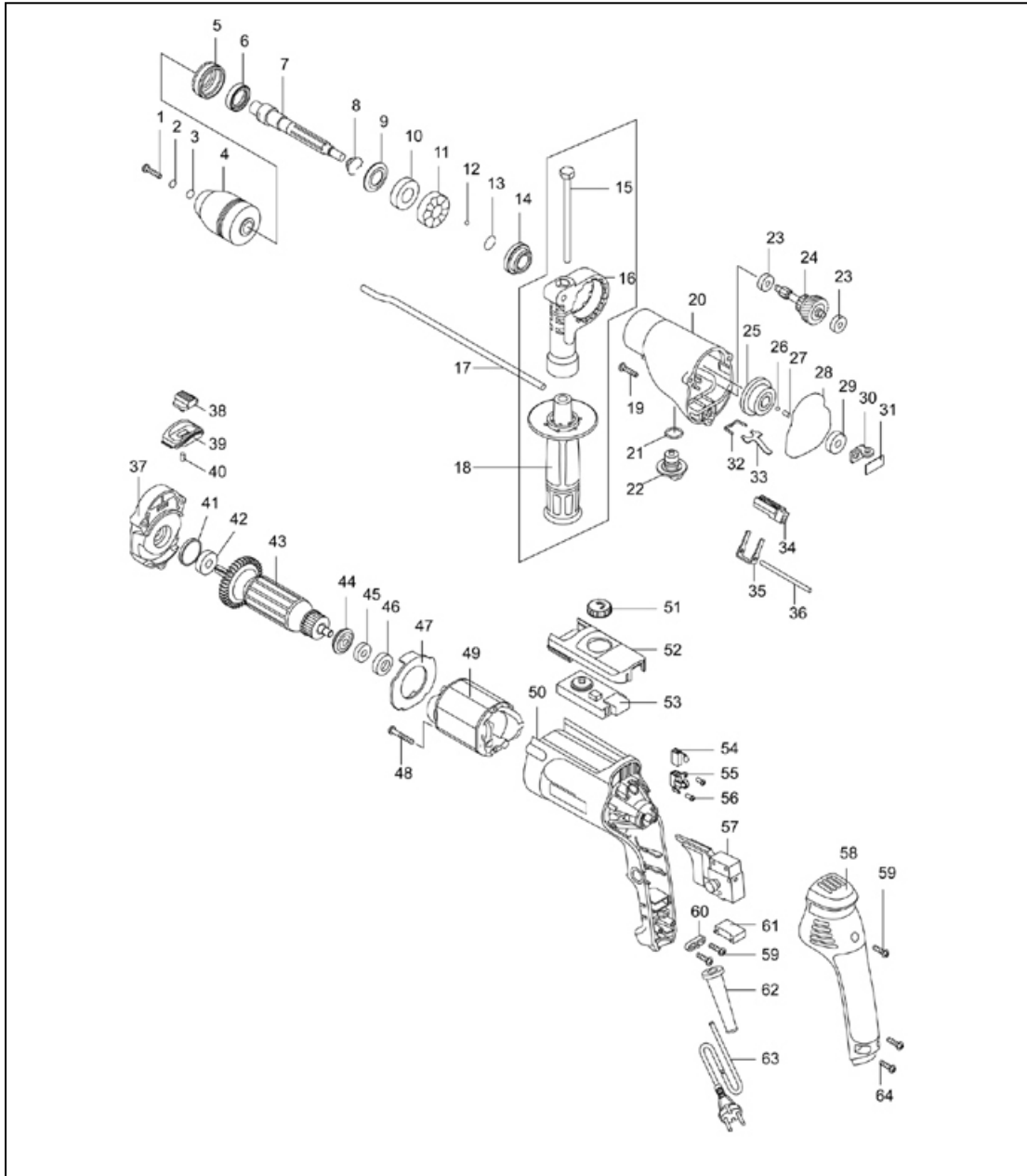



SPARE PARTS LIST (SEE SPECIFIC LOCATION)

PART NO.	DESCRIPTION	QUANTITY	PART NO.	DESCRIPTION	QUANTITY
1	SCREW M5 X 22	1	33	INSERTING PLATE	1
2	SPRING WASHER 5	1	34	GEAR TEETH	1
3	PLAIN WASHER 5	1	35	SPEED LEVER	1
4	CHUCK	1	36	FIXING PIN	1
5	BEARING COVER	1	37	MIDDLE COVER	1
6	SEAL	1	38	IMPACT BUTTON	1
7	SPRINDLE	1	39	BUTTON SEAT	1
8	IMPACT SPRING	1	40	PIN	1
9	SPRING SEAT	1	41	BEARING 609-2RZ	1
10	BEARING 6202-2R2	1	42	ROTAR ASSY	1
11	POSITIVE IMPACT BLOCK	1	43	DUST RING	1
12	STEEL BALL Φ 4	1	44	O RING 26 X 29 X 3	1
13	CIRCLIP 12	1	45	BEARING 607-22	1
14	STILL IMPACT BLOCK	1	46	607 BEARING SLEEVE	1
15	BOLT M 8 X 115	1	47	WING GUARD	1
16	HANDLE CLAMP	1	48	SCREW ST 4.2 X 70 F	2
17	DEPTH GAUGE	1	49	STATOR ASSY	1
18	SIDE HANDLE	1	50	HOUSING	1
19	SCREW ST 4.2 X 35F	3	51	SPEED ADJUST DIAL	1
20	GEAR BOX	1	52	CONSTANT POWER SEAT	1
21	O RING	1	53	CONSTANT POWER	1
22	SPEED CHAG KNOB	1	54	CARBON BRUSH	2
23	BEARING 606-2Z	2	55	BRUSH HOLDER	2
24	MIDDLE SHAFT AND GEAR	1	56	SCREW ST 2.9 X 8	4
25	II BIG GEAR	1	57	SWITCH	1
26	STEEL BALL	1	58	REAR COVER	1
27	IMPACT PIN	2	59	SCREW 4.2 X 12F	3
28	SEAL RING	1	60	CORD CLAMP	1
29	BEARING 608-2RZ	1	61	CAPACITOR	1
30	ADJUST BLOCK	1	62	CORD PROTECTOR	1
31	WASHER	1	63	CORD AND PLUG	1
32	SPRING	1	64	SCREW ST 4.2 X 16F	2

* NOTE: THE SPARE PARTS NO.51,AND NO. 53 ARE NOT USED FOR THE MODEL Z1J-HT-13.

INSTRUCTIUNI DE SIGURANTA PENTRU UNELTELE ELECTRICE



AVERTISMENT

CAND FOLOSITI O UNEALTA ELECTRICA, AR TREBUI LUATE IN CONSIDERARE PRECAUTIILE CE URMEAZA, PENTRU REDUCEREA RISCULUI DE ELECTROCUTARE, INCENDIU SI/ SAU VATAMARE CORPORALA. **CITITI SI INTELEGETI MANUALUL DE UTILIZARE INAINTE DE UTILIZAREA SCULELOR ELECTRICE**

MASURI DE SIGURANTA ELECTRICA DE BAZA

DUBLA IZOLARE. ACEASTA UNEALTA ESTE DUBLU IZOLATA DE LA BLOCUL DE ALIMENTARE DE LA RETEA FIIND ASTFEL INUTILA IMPAMANTAREA EI.

COMPATIBILITATEA VOLTAJULUI LA PRIZA SI VOLTAJULUI UNELTEI ELECTRICE. ASIGURATI-VA CA VOLTAJUL DE LA PRIZA SA FIE CUPRINS DE REZISTENTA ADITIONALA A SCULEI ELECTRICE.

EVITATI ELECTROSOCURILE. NU LUCRATI IN CONDITII DE UMEZEALA.

MASURI DE SIGURANTA PERSONALA GENERALA

FITI VIGILENTI. OPERAREA UNEI SCULE ELECTRICE NECESITA ATENTIE, CONCENTRARE SI CONTROL PENTRU EVITAREA LEZIUNILOR CORPORALE. ASADAR CAND UTILIZATI O ASTFEL DE UNEALTA NU TREBUIE SA FITI OBOSIT SI/SAU SUB INFLUENTA BAUTURILOR ALCOOLICE, A DROGURILOR SAU MEDICAMENTELOR.

FOLOSITI ECHIPAMENT DE PROTECTIE. FOLOSITI ECHIPAMENTUL DE PROTECTIE ADECVAT ASEMENEA OCHELARILOR DE PROTECTIE, MASTILOR DE PRAF, PANTOFILOR PLINI, DE SIGURANTA SAU A DOAPELOR DE PROTECTIE PENTRU URECHI, DE CATE ORI ESTE NECESAR.

IMBRACATI-VA ADECVAT. NU PURTATI HAINE LARGI SAU BIJUTERII ASEMENEA COLIERELOR CE POT FI PRINSE DE PARTILE UNELTELOR.

DISTANTATI ORICE UNEALTA DE REGLARE ASEMENEA CHEILOR FIXE. INAINTE DE A PORNII UNEALTA, DISTANTATI ORICE CHEI DE REGLARE PENTRU A EVITA ACCIDENTELE CAUZATE DE ARUNCAREA CELOR UITATE PE PARTILE ROTATIVE ALE SCULEI.

EVITATI PORNIRILE ACCIDENTALE. ASIGURATI-VA CA BUTONUL SA FIE PE POZITIA DE "OPRIT" INAINTE DE A CONECTA UNEALTA LA SURSA DE ALIMENTARE CU ENERGIE ELECTRICA

EVITATI ELECTROSOCURILE. PRINDETI UNEALTA DE MANERUL CU PROTECTIE SPECIALA CAND ESTE VORBA SA FOLOSITI SCULE DE GAURIT SAU TAIAT CE AR PUTEA VENI IN CONTACT CU FIRE ELECTRICE ASCUNSE.

PASTRATI UNEALTA SI MAINILE DUNEAVOASTRA CURATE. PASTRATI UNEALTA, IN SPECIAL MANERUL SI MAINILE DUMNEAVOASTRA CURATE, FARA URME DE ULEI SAU GRASIMI PENTRU O BUNA CONTROLARE A OPERATIEI.

TINETI COPIII SAU PERSOANELE NEINSTRUIE LA DISTANTA.

FOLOSIREA SI INGRIJIREA UNELTELOR ELECTRICE

NU SUPRASOLICITATI SCULELE. NU FOLOSITI SCULELE IN OPERATII PENTRU CARE NU SUNT DESTINATE.

FIECARE SCULA ESTE DESTINATA UNOR OPERATII SPECIFICE. O SCULA ELECTRICA DESTINATA UZULUI CASNIC NU TREBUIE FOLOSITA IN UZUL PROFESIONAL DE LUNGA DURATA

UNELTELE TREBUIE REPARATE DOAR DE PERSONAL CALIFICAT. ORICE UNEALTA CE NU POATE FI CONTROLATA DIN COMUTATOR, ESTE PERICULOASA SI TREBUIE REPARATA DE PERSONAL CALIFICAT

DECONECTATI UNEALTA DE LA SURSA DE ELECTRICITATE INAINTE DE ORICE INTERVENTIE. DECONECTATI DE LA SURSA DE ELECTRICITATE SI/ SAU DE LA ACUMULATORI INAINTE DE ORICE AJUSTARE, SCHIMBARE DE PIESE, DEPOZITARE SAU INTRETINERE.

PASTRATI UNELTELE IN LOCURI SIGURE. PASTRATI UNELTELE IN LOCURI USCATE SI CURATE, FARA A FI LA INDEMANA COPIILOR

INTRETINEREA PREVENTIVA A UNELTELOR.

- VERIFICATI PARTILE DETASABILE; VERIFICATI DACA TOATE SURUBURILE SUNT BINE STRANSE.
- GRESATI CU PASTE SPECIALE FIECARE PIESA PE CARE O SCHIMBATI.
- DUPA EXAMINAREA REGULATA A STARII ACCESORIILOR, VEDETI CE PIESE TREBUIE SCHIMBATE.
- CURATATI UNELTELE CU O CARPA IMBIBATA IN APA CU DETERGENT.

INSTRUCTIUNI DE SIGURANTA PENTRU BORMASINA

PURTATI ECHIPAMENT DE PROTECTIE. PURTATI INTOTDEAUNA OCHELARI SAU MASTI DE PROTECTIE A OCHILOR PENTRU A VA PROTEJA PRIVIREA DE POTENTIALELE PERICOLE.

NU INFASURATI FIRUL IN JURUL MAINII SAU MIJLOCULUI RISCAND SA FITI DEZECHILIBRATI IN TIMPUL LUCRULUI. NU PRINDETI TOATA BORMASINA, SAU NU TINETI MAINILE PREA APROAPE DE BURGHIU SAU CAPAT DE SURUBELNITA.

POZITIONATI-VA IN ASA FEL INCAT SA NU VA AFLATI INTRE BORMASINA, SAU MANER, SI ZID. DACA IN TIMPUL LUCRULUI CAPATUL DE SURUBELNITA RAMANE BLOCAT MOMENTUL DE TORSIUNE REACTIV AL MASINII VA POATE ZDROBI MAINILE SAU PICIOARELE.

CAND ATASATI UN ACCESORIU, INTRODUCETI TIJA ACESTUIA MULT IN MANDRINA PENTRU A EVITA PIERDEREA CONTROLULUI ASUPRA BORMASINII.

DUPA O FOLOSIRE INDELUNGATA FARFUL BURGHIULUI VA FI FIERBINTE, ASA CA ATUNCI CAND VETI DORI SA IL SCHIMBATI, EVITATI ORICE CONTACT CU PIELEA SI PURTATI MANUSI DE PROTECTIE.

NU FOLOSITI FORTA EXCESIVA. O PRESIUNE PREA MARE POATE REDUCE VITEZA BORMASINII REDUCAND ASTFEL EFICIENTA.ACEST LUCRU POATE DUCE LA SUPRASOLICITAREA MOTORULUI IN SINE

SIMBOLURI

IMPORTANT: ASIGURATI-VA CA SIMBOLURILE DESCRISE MAI JOS SE AFLA INSCRIPTIONATE SI PE BORMASINA DUMNEAVOASTRA . INTELEGHEREA LOR VA VA AJUTA SA STITI CUM SA FOLOSITI BORMASINA IN CONDITII SIGURE.

SIMBOL	DENUMIRE	EXPLICATII
V	VOLT	VOLTAJ
A	AMPER	CURENT
Hz	HERTZ	FRECVENTA
W	WATT	PUTERE
n0	TURATIE LA MERS IN GOL	VITEZA MOTORULUI INAINTE DE CONTACTUL CU SUPRAFATA DE LUCRU
.../MIN	ROTATII PE MINUT	NUMAR DE ROTATII/MINUT
0	"OFF"	POZITIA "INCHIS"
1, 2, 3, ...OU I, II, III,	SELECTOR DE VITEZA	UN NUMAR MARE INDICA O VITEZA MARE
	CLASA DE FABRICATIE II	DUBLA IZOLATIE
	IMPAMANTARE	LEGATURA DE IMPAMANTARE
	COLECTAREA DESEURILOR	ACEASTA SIGLA INDICA FAPTUL CA APARATELE ELECTRICE SI ELECTRONICE NU VOR FI ARUNCATE IMPREUNA CU GUNOIUL MENAJER, CI VOR FI PREDATE IN VEDEREA RECICLARII LA CENTRELE DE COLECTARE SPECIAL AMENAJATE, CONFORM HG448/2005 SI DIRECTIVA CONSILIULUI EUROPEAN 2002/96/EC

PRINCIPALELE FUNCTII ALE BORMASINII

BORMASINA DUMNEAVOASTRA POATE AVEA TOATE FUNCTIILE DE MAI JOS, SAU DOAR O PARTE DINTRE ACESTEA:, IN FUNCTIE DE MODEL

PARTILE COMPONENTE ALE BORMASINII

MODEL Z1J – HT – 13

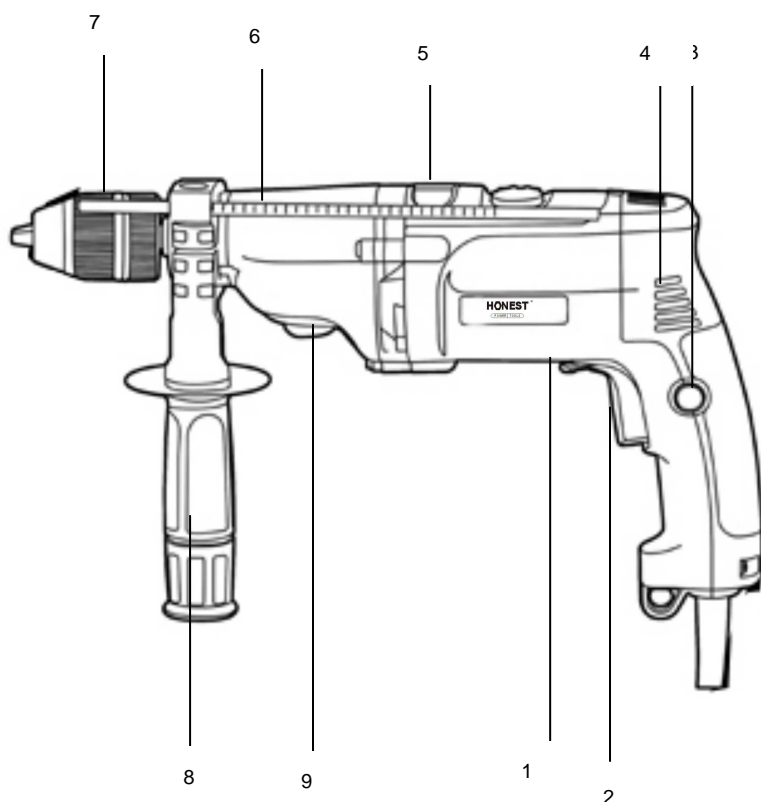

- | | | | |
|---|--|---|---|
| 1 | PARGHIE PENTRU SCHIMBAREA SENSULUI DE ROTATIE | 5 | SCHIMBATOR DE FUNCTII |
| 2 | COMUTATOR "PORNIT/OPRIT" CU VARIATOR DE VITEZA | 6 | TIJA DE LIMITARE A ADANCIMII DE GAURIRE |
| 3 | BUTON DE BLOCARE A COMUTATORULUI | 7 | MANDRINA |
| 4 | FANTE DE VENTILARE | 8 | MANER LATERAL |
| | | 9 | SELECTOR REGIM VITEZA |

OPERAREA CU BORMASINA

DESENELE SI/SAU SCHEMELE DE MAI JOS VA VOR AJUTA SA VA FAMILIARIZATI CU DIFERITELE FUNCTII PE CARE LE POATE INDEPLINI BORMASINA. **INAINTE DE A EFECTUA ORICE INTERVENTIE, BORMASINA TREBUIE SA FIE DECUPLATA DE LA SURSA DE ALIMENTARE CU ENERGIE ELECTRICA**

ASAMBLAREA

1. INTRODUCEREA SAU SCOATEREA BURGHILUI

ASEZATI PARGHIA INAINTE/INAPOI PE POZITIA „L”; STRANGETI CU FERMITATE MANDRINA CU O SINGURA MANA; IN PRIMUL RAND SLABITI SURUBURILR MANDRINEI PRIN PORNIREA BORMASINII LA O VITEZA MICA; INTRODUCETI BURGHIIUL IN INTERIORUL MANDRINEI; ASEAZATI PARGHIA „INAINTE/INAPOI” PE POZITIA „R” SI STRANGETI SURUBURILE MANDRINEI CU FERMITATE CU O SINGURA MANA; STRANGERE MANDRINEI SE VA FACE PRIN PORNIREA BORMASINII LA O VITEZA MICA (FIGURA 1)

PENTRU SCOATEREA BURGHILUI DIN MANDRINA RELUATI TOATE OPERATIILE ENUNTATE MAI SUS, DAR IN SENS INVERS.

2. INSTALAREA SAU SCOATEREA MANERULUI AUXILIAR

MANERUL AUXILIAR VA OFERA CONTROL SI SPRIJIN SUPLIMENTAR IN TIMPUL ACTIONARII UNELTEI ELECTRICE. ACEST MANER SE POATE REGLA CU 360° IN JURUL AXEI LU I DE ROTATIE (FIGURA 2)

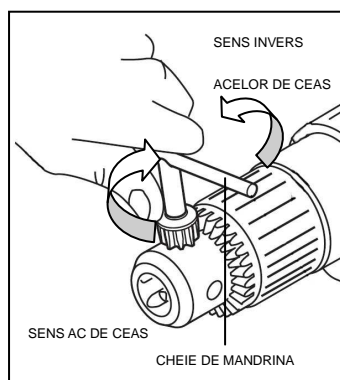

FIG.1

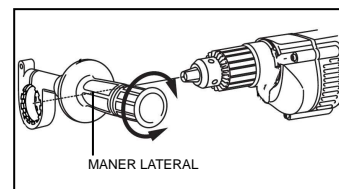

FIG.2

3. MONTAREA TIJEI DE LIMITARE A ADANCIMII

TIJA DE ADANCIME VA AJUTA LA REALIZAREA DE GAURI UNIFORME LA ACEEASI ADANCIME. DESFACETI MANERUL AUXILIAR SI INTRODUCETI TIJA DE LIMITARE A ADANCIMII IN GAURA DIN MANERUL AUXILIAR. REGLATI TIJA PANA LA ADANCIMEA DORITA DUPA CARE STRANGETI MANERUL AUXILIAR (FIGURA 3).

4. SCHIMBAREA PERILOR DE CARBUNE

PENTRU A MENTINE UN RANDAMENT RIDICAT AL MOTORULUI UNELTEI ELECTRICE VA RECOMANDAM SA EXAMINATI PERIODIC PERILE DE CARBUNE LA UN INTERVAL DE TIMP DE 2-6 LUNI. DEOARECE PERILE DE CARBUNE SUNT PARTE INTERNA A BORMASINII, INLOCUIREA ACESTORA TREBUIE SA FIE REALIZATA DE CATRE PERSONAL SPECIALIZAT.

5. MONTAREA SI DEMONTAREA MANDRINEI

PENTRU DEMONTAREA MANDRINEI SLABITI DISPOZITIVUL DE PRINDERE SI DESFACETI SURUBURILE DIN INTERIORUL MANDRINEI CU O SURUBELNITA PRIN ROTIREA EI IN SENSUL ACELOR DE CEASORNIC; PE URMA ALEGETI O CHEIE CU CAP HEXAGONAL CORESPUNZATOARE PE CARE O INTRODUCETI IN INTERIORUL MANDRINEI SI O VETI ROTI IN SENS INVERS ACELOR DE CEASORNIC (FIGURA 4)

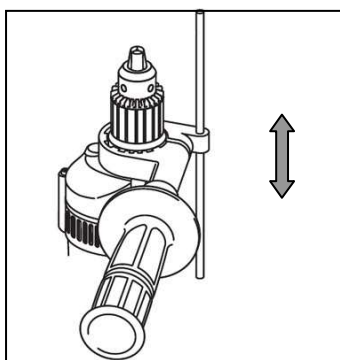

FIG.3

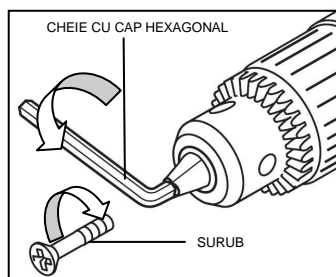

FIG.4

OPERAREA CU BORMASINA

1. FUNCTIA DE OPERARE IN REGIM CONTINUU

ELIBERATI COMUTATORUL „INCHIS/DESCHIS” INAINTE DE PORNIREA BORMASINII DUPA CARE APASATI BUTONUL DE BLOCARE PENTRU ACTIVAREA OPTIUNII DE LUCRU IN REGIM CONTINUU. DEZACTIVATI FUNCTIA DE LUCRU IN REGIM CONTINUU PRIN APASAREA COMUTATORULUI „INCHIS/DESCHIS” CEEA CE VA CONDUCE SI LA OPRIREA BORMASINII.

2. FUNCTIA DE SELECTARE A VITEZEI

BORMASINA POATE SA AIBA VITEZE VARIABILE CEEA CE-I PERMITE SA FUNCTIONEZE DE LA 0 LA 1200 ROT/MIN SI DE LA 0 LA 2900 ROT/MIN; SIMBOLUL „I” ESTE PENTRU VITEZA MICA SI SIMBOLUL „II” ESTE PENTRU VITEZA MARE (FIGURA 7). PENTRU REALIZAREA UNEI OPERATII DE GAURIRE DE PRECIZIE FOLOSITI O VITEZA MICA PENTRU MARCAREA LOCULUI SI A PUNCTULUI DE GAURIRE, IAR PE URMA MARITI VITEZA DE GAURIRE PENTRU STRAPUNGerea PIESEI DE PRELUCRAT. (FIGURA 6).

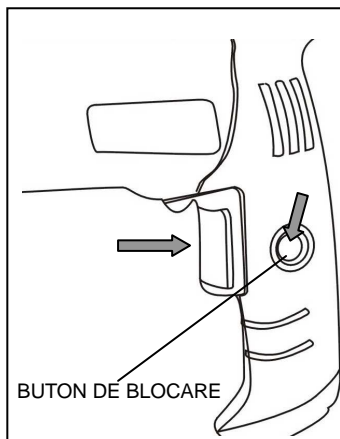

FIG.5

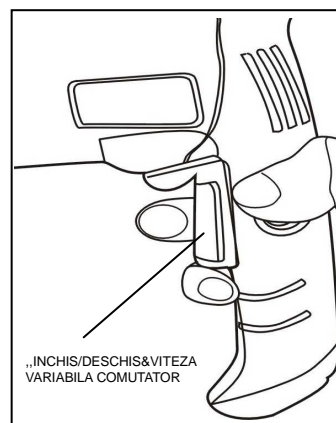

FIG.6



3. FUNCTIA DE INVERSARE A SENSULUI DE ROTATIE

CU BORMASINA SE POATE INVERSA SENSUL DE ROTATIE A BURGHIULUI; PENTRU A REALIZA MISCAREA DE ROTATIE INSPRE INAINTE MISCATI PARGHIA „INAINTE/INAPOI” PE POZITIA „R”, IAR PENTRU REALIZAREA MISCARII DE ROTATIE INSPRE INAPOI MISCATI ACEEASI PARGHIE PE POZITIA „L” (FIGURA 7).

DACA PARGHIA „INAINTE/INAPOI” SE AFLA PE POZITIA DE MIJLOC ATUNCI BORMASINA NU VA FUNCTIONA.

PENTRU A PREVENI DEFECTAREA BORMASINII SCHIMBATI SENSUL DE ROTATIE DOAR DUPA CE UNEALTA ELECTRICA S-A OPRIT COMPLET.

4. FUNCTIA DE GAURIRE SAU DE PERCUTIE A BORMASINII

PENTRU ALEGEREA FUNCTIEI DE GAURIRE POZITIONATI PARGHIA „GAURIRE/PERCUTIE” PE SIMBOLUL  CARE REPREZINTA GAURIRE, IAR PENTRU ALEGEREA FUNCTIEI DE PERCUTIE ASEZATI ACEEASI PARGHIE PE SIMBOLUL  CARE REPREZINTA PERCUTIE (FIGURA 8)

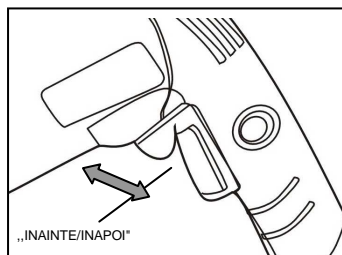

FIG.7

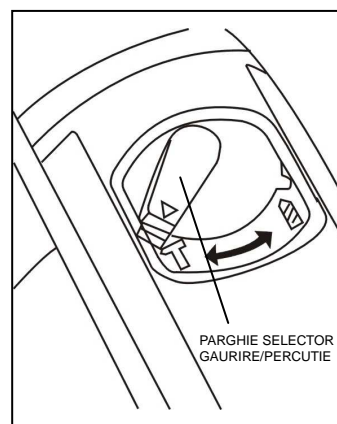

FIG.8

5. RECOMANDARI PRIVIND OPERAREA CU BORMASINA

• GAURIREA LEMNULUI SAU A MATERIALELOR PLASTICE

FIXATI PIESA DE PRELUCRAT DEOARECE ATUNCI CAND INCEPETI OPERATIA DE GAURIRE APARE RISCUL RANIRILOR PERSONALE PRIN RUPERA EI.

• GAURIREA METALELOR

PENTRU PRELUCRAREA UNEI PIESE METALICE PRIN GAURIRE REALIZATI MAI INTAI O GAURA DE DIMENSIUNI MAI MICI DUPA CARE MARITI ACEASTA GAURA PANA LA MARIMEA DORITA. UNEORI ESTE NECESAR SA LUBRIFIATI VARFUL BURGHIULUI PENTRU A USURA OPERATIA DE GAURIRE.

• GAURIREA IN LUCRARI DE ZIDARIE

UTILIZATI BURGHIE CU CAP VIDIA PENTRU OPERATII DE GAURIRE IN LUCRARI DE ZIDARIE DEOARECE PRESIUNEA APLICATA ASUPRA BORMASINII DEPINDE DE DURITATEA MATERIALULUI PRELUCRAT

DATE TEHNICE

MODEL	Z1J-KA9-13/16	
PUTERE CONSUMATA NOMINALA:	850 W	
INTENSITATEA NOMINALA	3.9 A	
TENSIUNE/FRECVENTA NOMINALA	230 V ~ 50 Hz	
DIAMETRUL MAXIM DE PRINDERE AL MANDRINEI:	13/16 MM	
TURATIA LA MERSUL IN GOL	0-2,900/0-1,200 RMP	
CAPACITATEA MAXIMA DE GAURIRE:	VITEZA MARE (0-2,900 RMP)	VITEZA MICA (0-1,200 RMP)
- <i>BETON</i>	<i>20 MM</i>	<i>.....</i>
- <i>LEMN</i>	<i>8 MM</i>	<i>16 MM</i>
- <i>METAL</i>	<i>25 MM</i>	<i>40 MM</i>
ZGOMOT SI VIBRATII		
- <i>NIVELUL DE PRESIUNE A ZGOMOTULUI</i>	<i>55.7 dB (A)</i>	
- <i>NIVELUL DE PUTERE A ZGOMOTULUI</i>	<i>66.7 dB (A)</i>	
- <i>NIVELUL VIBRATIILOR</i>	<i>25.4 M/S²</i>	
GREUTATE	3.2 KG	

ACCESORII

TABELUL CU ACCESORIILE STANDARD

CHEIE PENTRU MANDRINA	1 BUC.
TIJA DE LIMITARE A ADANCIMII DE GAURIRE	1 BUC.
MANER LATERAL	1 BUC.
PERII DE CARBON (CARBUNI)	1 PERECHE
MANUAL CU INSTRUCIUNI	1 BUC.

SCHEMA PARTILOR COMPONENTE

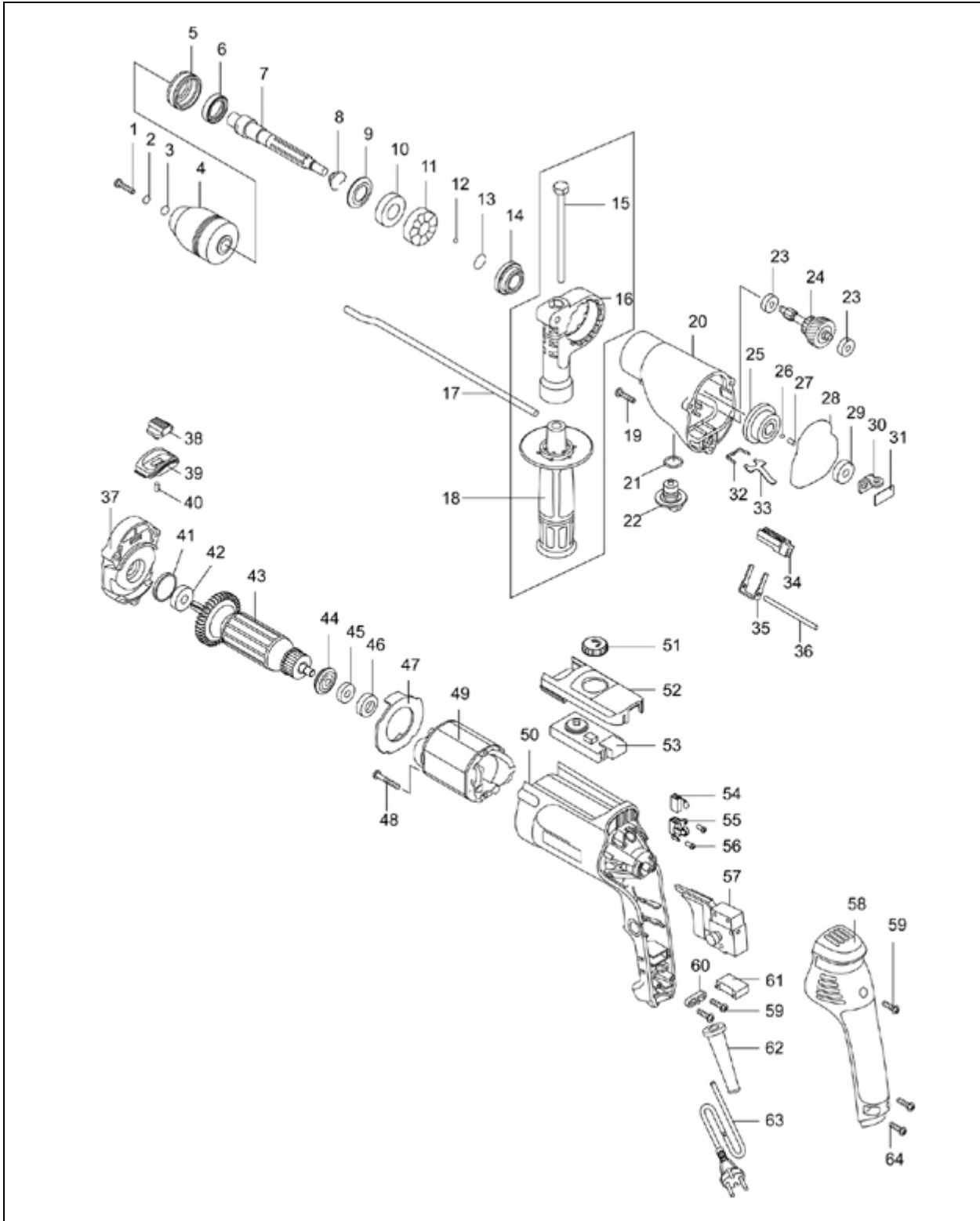

TABELUL PARTILOR COMPONENTE

NR.	DESCRIERE	BUC.	NR.	DESCRIERE	BUC.
1	SURUB M5X22	1	33	GARNITURA DE INTERCALARE	1
2	SAIBA ELASTICA 5	1	34	DINTE ROATA DINTATA	1
3	SAIBA PLATA 5	1	35	PARGHIE DE REGLARE VITEZA	1
4	MANDRINA	1	36	STIFT DE FIXARE	1
5	CARCASA RULMENT	1	37	CAPAC CENTRAL	1
6	DISPOZITIV DE ETANSARE	1	38	BUTON COMANDA PERCUTIE	1
7	AX	1	39	LOCAS BUTON	1
8	ARC DE PERCUTIE	1	40	PINION	1
9	LOCAS ARC	1	41	RULMENT 609-2RZ	1
10	RULMENT 6202-2R2	1	42	ANSAMBLU ROTOR	1
11	SABOT DE IMPACT	1	43	INEL DE PROTECTIE PRAF	1
12	BILA DE OTEL Ø4	1	44	GARNITURA ORING 26X29X3	1
13	SAIBA ELASTICA 12	1	45	RULMENT 607-22	1
14	SABOT RETINERE IMPACT	1	46	BUCSA RULMENT 607	1
15	SURUB M8X115	1	47	CAPAC FLUTURE	1
16	SURUB STRANGERE MANER	1	48	SURUB ST4.2X70F	2
17	TIJA DE ADANCIME	1	49	ANSAMBLU STATOR	1
18	MANER LATERAL	1	50	CARCASA	1
19	SURUB ST4.2X35F	3	51	SCALA REGLARE VITEZA	1
20	CAPAC ANGRENAJ	1	52	SUPORT PLACA CONTACT	1
21	GARNITURA ORING	1	53	PLACA DE CONTACT	1
22	PARGHIE SCHIMBARE VITEZA	1	54	PERIE CARBUNE	2
23	RULMENT 606-2Z	2	55	SUPORT PERIE	2
24	AX CENTRAL	1	56	SURUB ST2.9X8	4
25	MECANISM MOTOR	1	57	COMUTATOR	1
26	BILA DE OTEL	1	58	CARCASA POSTERIOARA	1
27	DISPOZITIV PERCUTIE	2	59	SURUB 4.2X12F	3
28	INEL DE ETANSARE	1	60	CLEMA FIXARE CABLU	1
29	RULMENT 608-2RZ	1	61	CONDENSATOR	1
30	SABOT DE REGLAJ	1	62	MUFA PROTECTIE CABLU	1
31	SAIBA	1	63	CABLU ELECTRIC CU STECHER	1
32	ARC	1	64	SURUB ST4.2X16F	2

• NOTA: PARTILE COMPONENTE DE LA POZITIILE 51 SI 53 NU APAR IN CONSTRUCTIA MODELULUI Z1J-HT-13.