

MANUAL DE UTILIZARE/ USER'S MANUAL
HIDROFOR / HYDROPHORE
JET 100L / JET 150L
24L / 36L / 50L



INFORMATII REPARATII IN GARANTIE PE ULTIMA PAGINA



Va multumim pentru achizitionarea acestui produs EVOSANITARY, fabricat conform celor mai inalte standarde de siguranta si de functionare.



Avertizare! Pentru siguranta dumneavoastra cititi cu atentie acest manual si instructiunile generale de siguranta inaintea utilizarii echipamentului. Nerespectarea acestor reguli poate avea ca rezultat producerea electrocutarilor, a incendiilor si/sau a ranirilor personale.

Simboluri

Simbolurile utilizate in manual sau pe produs au urmatoarele semnificatii:

	Atentie!		Produsul este in conformitate cu standardele de siguranta ale Directivelor Europene
	Cititi manualul de utilizare		Izolatie dubla

Masuri de siguranta generale pentru uneltele electrice

Masuri de siguranta a echipamentului in exploatare



ATENIE! Verificati intotdeauna ca tensiunea de alimentare sa corespunda cu cea inscrisa pe placuta echipamentului.

- Nu rasuciti cablul electric de alimentare al hidroforului
- Nu transportati hidroforul tinandu-l de cablul electric si nu trageti de cablul electric pentru a-l scoate din priza.
- Tineti cablul electric de alimentare al hidroforului la distanta fata de sursele de caldura, de petele de ulei, de grasimi, de obiectele ascutite si sursele care emana caldura.
- Verificati stecherul si cablul electric in mod regulat si in caz de deteriorare a acestora apelati la un electrician autorizat.
- Nu suprasolicitati hidroforul! El poate fi folosita in conditii de siguranta daca sunt respectati parametrii de exploatare care o caracterizeaza. Nu utilizati echipamentele electrice cu un alt scop fata de cel pentru care sunt destinate.

Service

- Repararea trebuie realizata numai de catre personal autorizat prin inlocuirea cu accesorii si piese de schimb originale pentru a se evita producerea accidentelor datorate reparatiilor necorespunzatoare.

Masuri de siguranta specifice hidroforului

- Nu utilizati hidroforul pentru transportul lichidelor abrazive sau agresive, intrucat acesta se poate defecta sau distruge.
- Temperatura lichidului transportat nu trebuie sa depaseasca 35°C in functionare continua.
- Hidroforul nu trebuie sa functioneze fara lichid.
- Instalarea trebuie realizata de catre personal autorizat.

Domeniu de utilizare.

Hidroforul se va utiliza pentru pomparea si distribuirea apei curate in instalatii casnice dupa cum urmeaza:

- Pomparea si distributia apei in instalatii casnice cu functionare continua sau intermitenta.
- Cresterea de presiune in retea pentru distributie apa.
- Irigatii la scara redusa.
- Golirea rezervoarelor sau bazinelor.

NU ESTE PROIECTAT PENTRU UZ INDUSTRIAL.



ATENTIE ! Hidroforul este proiectat si construit pentru pomparea si distributia apei fara continut de substante explozive , particule solide sau fibre,cu o densitate de 1kg/dmc si o viscozitate cinematica de 1mm²/ s sau a lichidelor non-agresive chimic.

Pregatirea pentru punerea in functiune



ATENTIE! IN CAZUL IN CARE APAR ZGOMOTE ANORMALE IN FUNCTIONARE OPRITI IMEDIAT UNEALTA SI ADRESATI-VA UNUI SERVICE AUTORIZAT PENTRU CONSTATARI SI REPARATII.



ATENTIE! Dacă există o conducta de aspirație, pot trece pina la 4 minute de la pornirea pompei până ce este livrată apă. Această perioadă depinde de lungimea și diametrul conductei de aspirație

Verificarea hidroforului inainte de instalare:

- Verificati daca ambalajul nu prezinta zone deteriorate sau urme de lovituri puternice; daca acestea sunt evidente semnalati-le persoanei responsabile cu livrarea.
- Pozitionati hidroforul pe o suprafata plana cat mai aproape de sursa de apa.
- Respectati distantele minime fata de pereti astfel incat sa permita functionarea si realizarea operatiilor de intretinere in conditii de siguranta.

Zona de lucru:

- Inainte de instalarea sorbului in pozitia de lucru asigurati-va ca nu exista nisip sau sedimente solide.In cazul existentei acestora curatati foarte bine amplasamentul sorbului.
- Hidroforul functioneaza in pozitie orizontala.
- Este foarte important ca nivelul apei sa nu coboare niciodata sub sorbul pompei.
- **PERICOL DE INGHET!** In situatia in care pompa ramane inactiva la temperaturi sub 0°C,asigurati-va ca nu exista apa reziduala care poate ingheta si prin urmare poate distruge componentele hidroforului

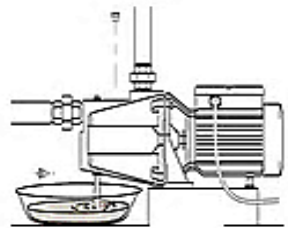

Conexiune hidraulica:

- Montati hidroforul intr-un camin sapat in apropierea putului. Caminul va fi realizat astfel incat sa asigure protejarea impotriva inundatiilor, inghetului si deasemenea sa asigure o buna aerisire cu scopul de a evita formarea condensului.
- Utilizati tevi cu diametrul corespunzator dotate cu racorduri filetate si insurubati-le pe stuturile de aspiratie si refulare ale electropompei.
- Verificati daca tevile sunt ferm fixate astfel incat greutatea lor sa nu deterioreze corpul pompei.
- Traseul tevilor de apa nu se va executa peste partea superioara a motorului electric sau a presostatului deoarece riscati deteriorarea acestora.

Pe conducta de aspiratie se vor monta obligatoriu:

- Un sorb cu supapa de sens in capatul introdus in put sau
- O supapa de siguranta pe traseul orizontal al conductei, langa pompa.

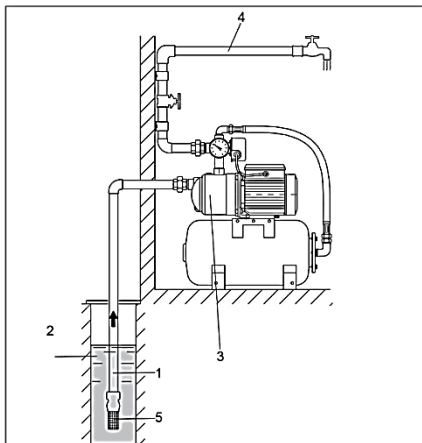

Montaj hidrofor - put:

- 1 - Conducta Aspiratie
- 2 - Put
- 3 - Hidrofor
- 4 - Conducta Refulare
- 5 - Sorb

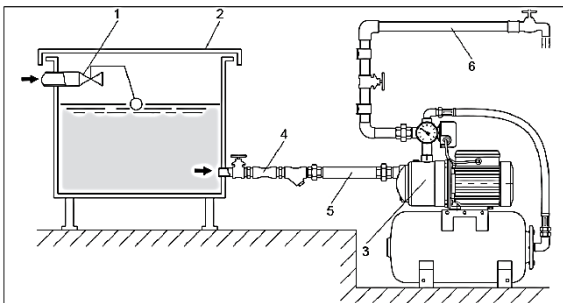

Montaj hidrofor - vas tampon:

- 1 - Robinet plutitor
- 2 - Vas tampon
- 3 - Hidrofor
- 4 - Supapa de sens
- 5 - Conducta de aspiratie
- 6 - Conducta de refulare

Pornirea hidroforului



ATENȚIE! Nu porniți hidroforul până când pompa nu a fost umplută cu lichid.

- Se desface surubul de aerisire a pompei (aflat in partea superioara a pompei).
- Se toarna apa curata in pompa si in conducta de aspiratie pana cand apa curge din electropompa.
- Se strange surubul de aerisire la loc.
- Se alimenteaza electric pompa.
- Daca pompa livreaza apa inseamna ca amorsarea a reusit. In caz contrar se reiau operatiunile de amorsare.
- Verificati daca sunt pierderi/scurgeri pe circuitul hidraulic.
- Asigurati-va ca pompa nu vibreaza anormal, nu are un nivel de zgomot ridicat si nu are variatii de presiune si curent absorbit.
- Verificati presiunea aerului din vasul de expansiune cu un manometru (1,5-1,6 bar) inainte de amorsare. Presiunea aerului din vasul de expansiune se va verifica periodic (o data la 2-4 luni) pentru a preveni deteriorarea membranei.
- Alimentati hidroforul la o sursa cu tensiune electrica. Asteptati cateva minute pana cand amorsarea este completa si apa care curge pe robinetul instalatiei nu mai contine bule de aer.

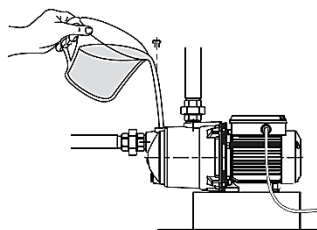

- Inchideti toate robinetele si lasati hidroforul sa functioneze pana la presiunea de oprire automata (la atingerea acesteia, presostatul va decupla pompa de la alimentarea cu energie electrica).

Caracteristica H (m col H₂O) – Q (l/ min) a pompei JET 100 L

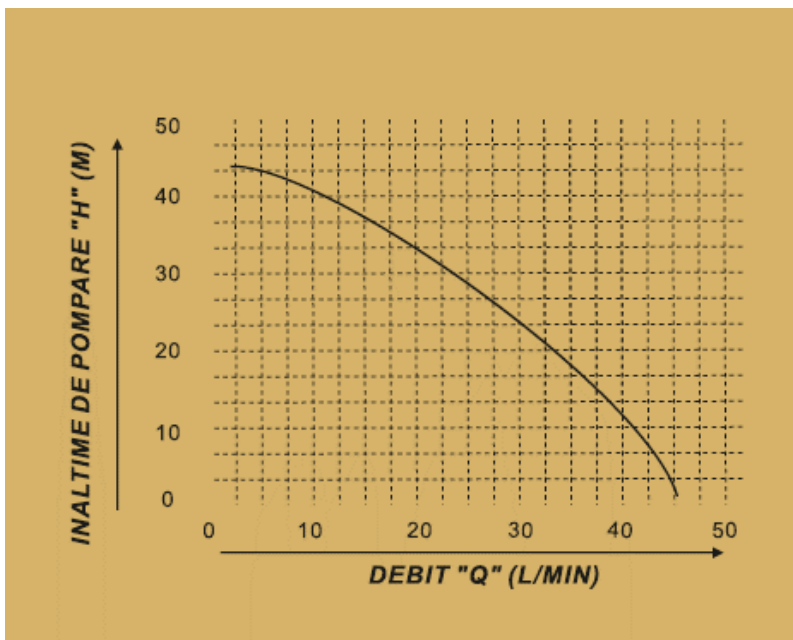

Caracteristica H (m col H₂O) – Q (l/ min) a pompei JET 150 L

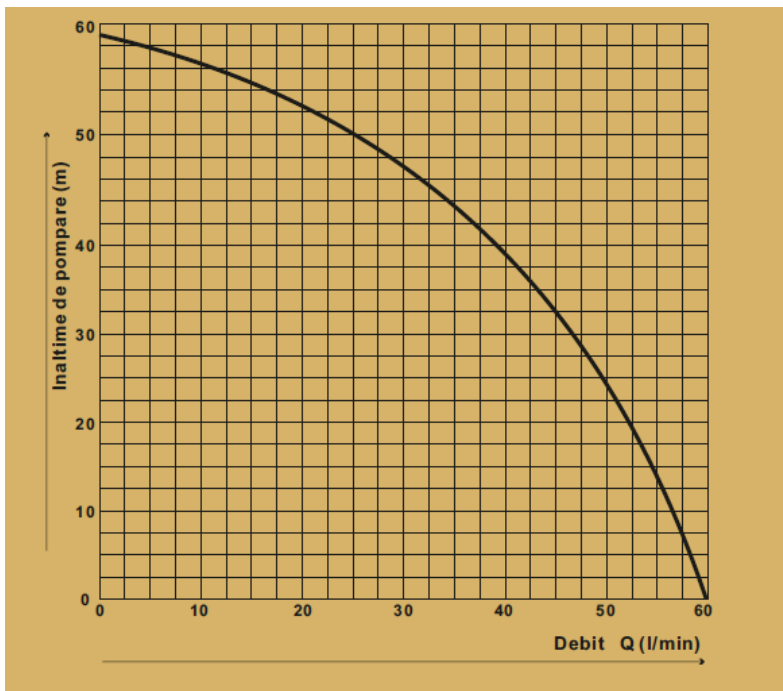

Conexiune electrica

- Este recomandata conectarea pompei la un circuit electric dedicat.
- Aceste hidrofoare cu motoare monofazate sunt dotate cu protectie termica si pot fi conectate direct la retea.

ATENȚIE! In cazul supraincalzirii motorului hidroforul se opreste automat. Dupa racire va porni din nou in mod automat, fara a fi necesara nici o interventie.

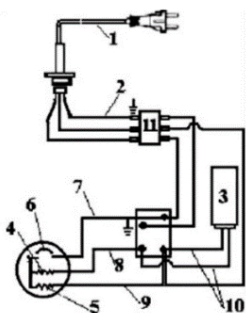

1. cablu de alimentare
2. cablu de împământare
3. condensator
4. stator
5. rotor
6. motor
7. conductor motor
8. conductor motor
9. conductor motor
10. fire condensator
11. presostat

Date tehnice

Tip pompa

JET 100 L

JET 150 L

Putere	750W	1100W
Tensiune / Frecventa	230V/50Hz	
Capacitate rezervor	24 / 36 / 50 L	
Presiune membrana elastica rezervor	1.5 bar	
Limite ajustare presostat	1.4-2.8 bar	
Debit maxim	55 L/ min	60 L/min
Temperatura maxima lichid pompat	35°C	
Adancime maxima de aspiratie	9m	9m
Inaltime maxima de pompare	45m	58m
Racorduri intrare/iesire	1 - 1"	
Tip motor	Cu ventilatie fortata	
Numar poli	2	
Clasa izolatie	F	
Grad protectie	IP 54	
Ciclu functionare	S1 - continuu	
Protectie la suprasarcina	Termica, cu resetare automata	
Material corp pompa	Fonta	
Etansare pe arbore	Presetupa mecanica	
Rulment	Capsulat cu bile	
Presiune sonora	LwA=85 dB(A)	

Curatare si intretinere



ATENTIE! Inainte de orice interventie asupra echipamentului, deconectati alimentarea cu energie electrica de la retea.

Curatare

- Pastrati curate fantele de acces ale difuzorului pentru a preveni supraincalzirea motorului si scaderea performantelor pompei
- NU utilizati solventi (ca de exemplu : petrol si derivati, alcool) intrucat acestia pot deteriora partile din plastic.

Intretinere

Echipamentul nostru a fost proiectat astfel incat sa poata fi utilizat pentru o perioada indelungata cu un minimum de intretinere. Nu necesita nici un fel de ungere suplimentara, datorita lubrifiantilor long-life utilizati de producator pentru componentele in miscare.

Asistenta tehnica

Probleme	Cauze	Masuri de remediere
Motorul nu porneste sau se opreste in timpul functionarii	Protectia termica.	Daca motorul este supraincalzit, nu va functiona. Asteptati racirea motorului 20-30 min
	Conexiune electrica incorecta	Verificati conexiunea electrica.

	Cablu electric intrerupt	Inlocuiti cablul electric.
	Defectiuni la motor sau condensator	Contactati reteaua de service HGT
	Tensiune de alimentare scazuta.	Verificati tensiunea sursei de alimentare .
	Rulmenti blocati	Contactati reteaua de service HGT
Pompa functioneaza dar nu livreaza apa sau livreaza o cantitate insuficienta	Pompa dezamorsata	Amorsati pompa
	Adancime de aspiratie prea mare	Corectati adancimea de aspiratie conform specificatiilor tehnice
	Conducta de aspiratie insuficient imersata	Verificati adancimea de imersie a conductei
	Sorb infundat sau pompa blocata de impuritati	Curatati sorbul sau pompa
	Patrunderea aerului in conducta de aspiratie.	Dupa verificarea imbinarilor, asigurati etansarea perfecta.
	Patrunderea aerului in pompa prin garniturile mecanice.	Inlocuiti garniturile mecanice.
Pompa vibreaza sau produce prea mult zgomot in timpul functionarii	Tevi fixate incorect	Fixati tevine
	Rulment uzat	Contactati reteaua de service HGT
	Ventilator motor fixat necorespunzator	Contactati reteaua de service HGT

EN

Thank you for buying this EVOSANITARY product, manufactured according to the highest safety and performance standards



WARNING! For your own safety, read this manual and the general safety Instructions carefully before using the appliance. Your power tool should only be given to other users together with these instructions.

Symbols

In this manual and/or on the machine the following symbols are used:

	Warning/Danger!		In accordance with essential applicable safety standards of European directives
	Read manual before use		Double insulated

General power tools safety warnings

Electrical safety



Always check that the power supply corresponds to the voltage on the rating plate.

- Do not abuse the cord. Never use the cord for carrying, lifting or operating the pump
- Keep cord away from heat, oil, sharp edges or moving parts. Damaged or entangled cords increase the risk of electric shock.
- Check plug and power cord regularly and in case of damage call to a qualified personnel.
- Do not overload the pump! It can be used safely if operating according to parameters. Do not use power tools for a different purpose than the one for which they are intended.

Service

Your power tool should be serviced by a qualified specialist using only standard spare parts. This will ensure that it meets the required safety standards.

Specific safety instructions for hydrophore

- Abrasive or aggressive liquids transported lead to damage and destruction booster system.
- Liquid temperature must not exceed transported 35 ° C in continuous operation.
- Installation should be performed by qualified personnel.

Application

- Pumping and distribution of water in domestic installations with continuous or intermittent operation.
- Increased pressure in the water distribution network.
- Small-scale Irrigation.
- Emptying containers or tanks.

IT IS NOT DESIGNED FOR PROFESSIONAL USE.



This hydrophore is built up for pumping water, free from explosive substances, solid particles and fibers, with a density of 1kg/dmc and a kinematic viscosity of 1mm² / s and chemically non-aggressive liquids.

Assembly



WARNING! In case of any abnormal noise, immediately turn off the tool and contact an authorized service facility for repairs



WARNING! If there is a suction pipe, it may take up to 4 minutes after start the pump until water is delivered. This period depends on the length and diameter of suction pipe

Checking of the hydrophore before installation

- Check if the packaging shows no tears or dents strong; if they are obvious notify the person responsible for delivering them.
- Place hydrophore on a flat surface as close to the water source.
- Respect the minimum distances from walls so as to allow the operation and implementation of maintenance operations safely.

Site of installation

- Before immersing the pump in the pit or tank, ensure that the place is free from sand and solid sediment. In case there is sediments, clean thoroughly the place.
- Hydrophore is working in horizontally position.
- Keep the sorb above the bottom of pit as to avoid suction of any deposit form after installation.
- It is very important to ensure that water level never falls below the body of pump.
- **DANGER OF FROST!** When the pump remains inactive at temperature of less than 0°C, it is necessary to ensure that there is no water residue that might freeze, and cause cracking of pump components.

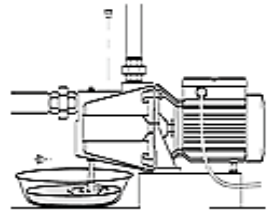

Piping

- Mount hydrophore in a home near the well. Protection will be made to ensure protection against floods, frost and also to ensure proper ventilation to avoid condensation.
- Use the proper diameter pipes fitted with threaded connections and screw them on the suction and discharge nozzles of the pump.
- Check that the pipes are firmly fixed so that their weight does not damage the pump body.
- Route water pipes will not run over the top of the electric motor or the switch because you risk damaging them.
- Suction pipe must be fitted with a non-return valve and sorb to prevent ingress of foreign bodies in the system.
- To the discharge pipe at the outlet of the electric pump installed a non-return valve and a valve

On the suction pipe will be installed mandatory:

- **A check valve in the end placed in the well or**
- **A safety valve on the horizontal route of the pipeline, near the pump.**

Starting the pump:



WARNING! DO NOT START THE PUMP WITHOUT WATER

- Unscrew the vent screw of the pump (located at the top of the pump).
- Pour in clean water in the suction pipe until the pump is fill with water.
- Put the vent screw back to his place.
- Plug the pump of the electrical network
- If the pump delivers water means you succeeded.
- If the pump don't deliveres water resume operarions above.
- Make sure that the pump does not vibrate abnormally, has a high noise level and has no pressure variations and input current.
- Check the air pressure in the expansion vessel with a pressure gauge (1.5-1.6 bar) before priming. The air pressure in the expansion tank should be checked periodically (every 2-4 months) to prevent damage to membranes.
- Power supply hydrophore to a power source. Wait a few minutes until priming is complete and flowing water on tap installation contains no air bubbles.
- Close all valves and let hydrophore work to automatic stop pressure (reaching its pump pressure switch clips from the power supply).

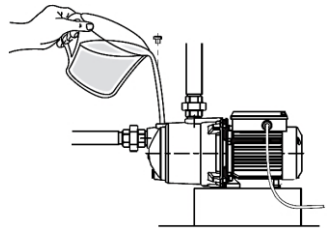

Grafic H-Q for Jet 100 L

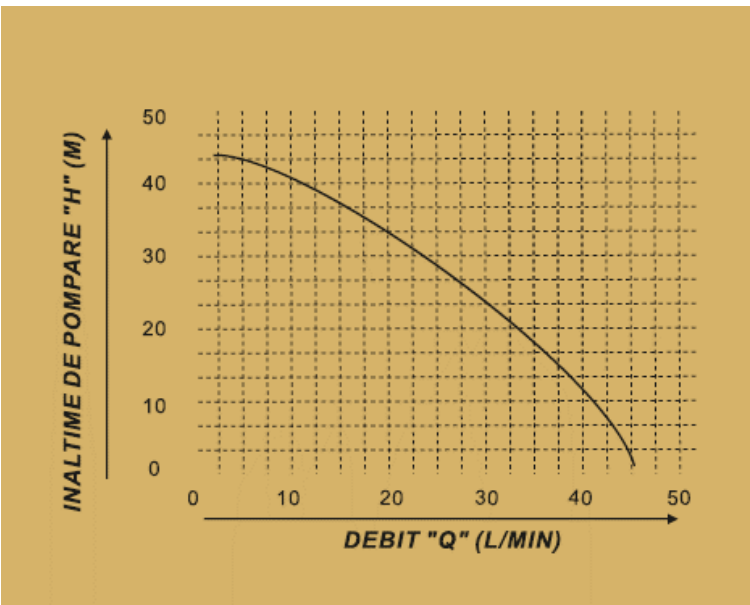

Grafic H- Q for Jet 150 L

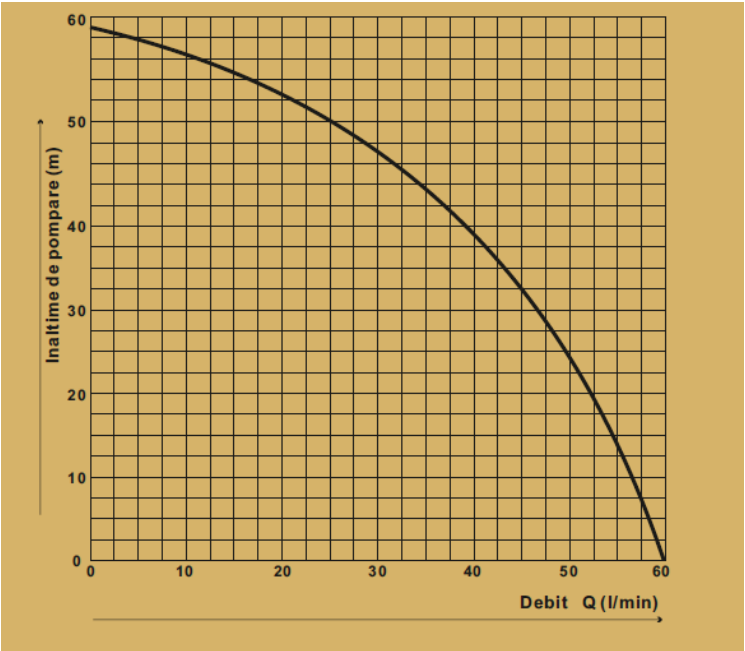

Electrical connection

- Is advisable to connect the pump to a dedicated power line.
- These pumps with single-phase motor are provided with a built-in thermal overload protection and could be connected directly to the power grid.



Warning! If the motor is overloaded it stops automatically. Once it has cool down it starts again automatically without requiring any manual intervention.

- Connect the pump cable to the electric pane, as below:

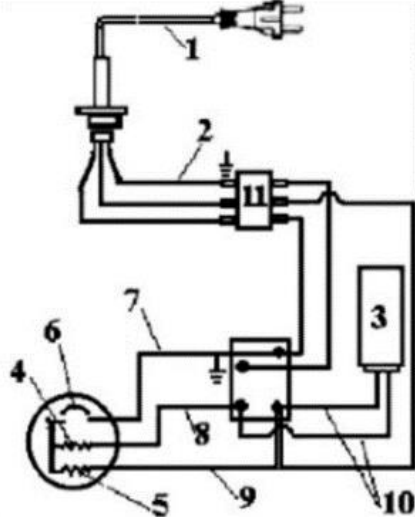

Legend:

1. Electric cable
2. Earthing cable
3. Capacitor
4. Stator
5. Rotor
6. Engine
7. Conductor motor
8. Conductor motor
9. Conductor motor
10. Capacitor wire
11. Pressure switch

Cleaning and maintenance



Before performing any work on the equipment, pull the power plug.

Cleaning

- Keep the inlet slots of the machine clean to prevent overheating of the engine.
- Never use solvents such as petrol, alcohol, ammonia water, etc. These solvents may damage the plastic parts.

Maintenance

Our machines have been designed to operate over a long period of time with a minimum of maintenance. In normal operation the pump does not require any type of maintenance, thanks to the oil bath lubricated seal and to the grease-for-life bearings.

Technical data

Pump type	JET 100 L	JET 150 L
Power	750W	1100W
Voltage / Frequency	230V/50Hz	
Tank capacity	24 / 36 / 50 L	
Max pressure tank membrane	1.5 bar	
Pressure switch settings	1.4-2.8 bar	
Maximum flow	55 L/ min	60 L/min
Liquid temperature range	35°C	
Maximum immersion	9m	9m
Maximum height	45m	58m
Connections Inlet/outlet	1 - 1"	
Electric motor type	Forced ventilation	
Pole numbers	2	
Insulation class	F	
Protection	IP 54	
Working cycle	S1 - continuous	
Overload protection	Thermal, automatic	
Pump body material	Cast iron	
Shaft sealing	Mechanical seal	
Bearing	Sealed, with balls	
Sound pressure level	LwA=85 dB(A)	

Storage

- Store it out of the reach of children, in a stable and secure position, dust-free and avoid too high and too low temperatures.
- Protect it from exposure to direct sunlight. Keep it in the dark, if possible.